

IMPORTANT: You must read the installation and owner's manual provided with the grill.

INSTALLER: Leave these instructions with consumer. **CONSUMER:** Retain for future reference.

1-Safety

CAUTION: WHEN INSTALLING UNIT, BE AWARE OF ENCLOSURE REQUIREMENTS; YOU MUST VENT UNIT IN ACCORDANCE WITH YOUR OWNER'S MANUAL. FAILURE TO DO SO MAY RESULT IN A FIRE OR EXPLOSION CAUSING PROPERTY DAMAGE, BODILY INJURY, OR DEATH.

This grill must be installed in accordance with local codes and ordinances, or, in the absence of local codes, with either the latest National Fuel Gas Code (ANSI Z223.1/NFPA 54), and Natural Gas and Propane Storage and Handling Installation Code (CSA-B149.1).

This appliance and its individual shutoff valves must be disconnected from the gas-supply piping system when testing the system at pressures in excess of ½ psig. This appliance must be isolated from the gas-supply piping system by closing its dedicated manual shutoff valve during any pressure testing of the gas-supply system at pressures up to and including ½ psig.

This unit is designed for outdoor use only. DO NOT use this unit inside a building, garage, or enclosed area (see paragraph below). DO NOT use this unit in or on a recreational vehicle or boat.

Important: If installing this unit in a **COMBUSTIBLE** enclosure, the correct RHP insulating liner must be used. Consult the liner instructions for cutout dimensions and installation.

A minimum 5 foot clearance is required between the countertop and the overhead construction. **DO NOT install under combustible overhead construction without a suitable UL710 or ULCS646 approved heavy duty vent hood.** When installed under non-combustible overhead construction, an exhaust hood is highly recommended. **When using an exhaust hood:** the area above the cooking surface of the grill must be covered with a hood larger than the cooking area of the grill, and with a minimum of 1200 CFM (cubic feet per minute) for proper outdoor application. Custom spacers must be constructed entirely of non-combustible materials only. Custom soffits may be constructed of wood, metal framing, etc.

Installation must be performed by a qualified professional service technician.

2-Unpacking

Carefully unpack the unit, removing all packing material and protective film (including the clear film on the drip tray). Verify that all parts have arrived undamaged by consulting the parts list in the owner's manual. Remove foam packed hardware. (See Fig. 2-1.)

Consult the parts list in the owner's manual. If any parts are missing or damaged, immediately contact the Fire Magic dealer before beginning installation.

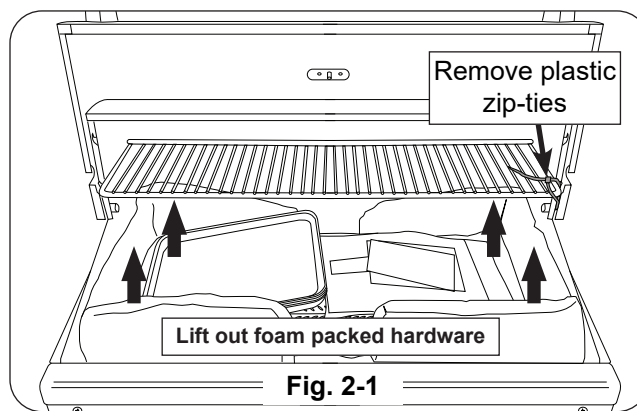

3-Installation

Location

Refer to the INSTALLATION REQUIREMENTS section of your grill owner's manual for complete details.

CAUTION: Wind blowing into or across the rear oven lid vent (Fig. 3-2) can cause poor performance and/or dangerous overheating. Orient the grill so that the prevailing wind blows toward the front of the grill (Fig. 3-1).

CAUTION: To prevent dangerous overheating, the rear of the unit must have a minimum clearance of 4" from any backsplash/non-combustible wall.



Grill Placement

Slide the unit into the enclosure cutout. The control panel must be flush with the enclosure face as shown in Fig. 3-4. The front support adjustment bolts MUST be used to provide support to the hangers. See Fig. 3-5.

Proper grill airflow (front-to-back) must be maintained as shown in Fig. 3-6. Do not block the front air inlet. **It is not necessary to remove the control panel or knobs for installation.**

Connect Gas Supply

These quick start instructions assume a **natural gas or household propane** configured unit. **See main instructions for propane cylinder units.**

Note: This section is only an overview of installation to the gas supply. Refer to the grill owner's manual for complete grill installation details.

Turn OFF the gas supply at the source. Run the attached flex connector routed under the left side of the unit to the gas supply stub. Then connect the flex connector to the gas supply with a flare-to-NPT adapter (Fig. 3-3). Use a pipe joint compound resistant to all gasses on all NPT pipe fittings **except flare fittings.**

Turn all burner control knobs to the **OFF** position. Turn the gas supply on. Then carefully check all gas connections for leaks with a brush and half-soap/half-water solution before lighting. **NEVER USE A MATCH OR OPEN FLAME TO TEST FOR LEAKS.**

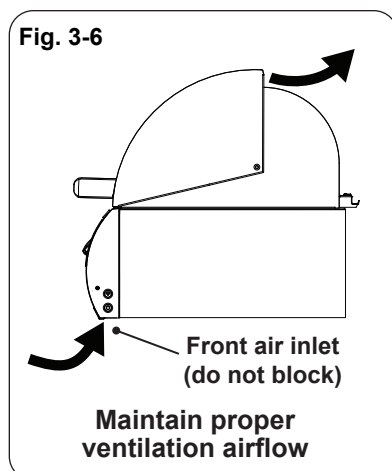
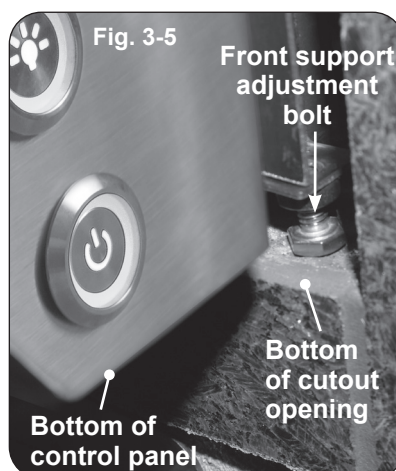
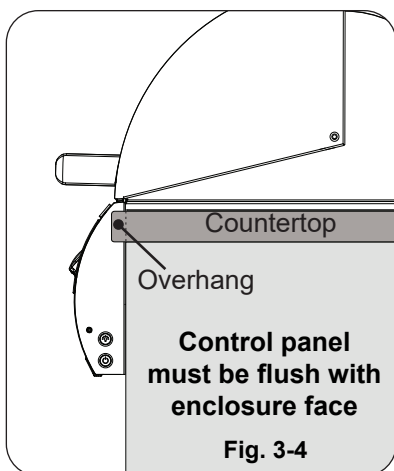
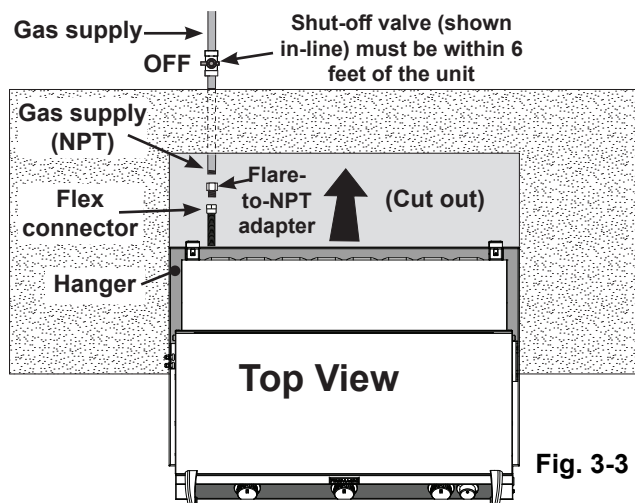

4-Grill Setup

Parts Placement Checklist

Place the following items according to their position and orientation in Fig. 4-1:

Flavor grids, cooking grids, backburner cover, drip tray, and meat probe (if applicable).

Leave pre-installed E-burners in place to maintain proper alignment.

Flavor Grids

Note: Flavor grids are not to be used over infrared burners.

Carefully rest the flavor grid with the pre-attached left panel onto the front and rear flavor grid rests while ensuring the flavor grid cutout clears the left-most lighting tube. Repeat for the second flavor grid with the pre-attached right panel and place it on the right side of the grill. Then take the inner grid(s) and install between the left and right flavor grids.

Cooking Grids

Place the cooking grids using the grid lifter.

Backburner Cover(s)

Hook the backburner cover(s) over the top of the backburner(s) to protect when it is not in use. Remove cover(s) before use.

Drip Tray(s)

Place a liner into the drip tray(s) and insert into the bottom front of the control panel opening.

Meat Probe (if equipped)

Connect the meat probe to the right side of the control panel for temperature readings on the digital thermometer (if equipped).

IMPORTANT: See your grill owner's manual for complete installation details.

Replacement parts can be ordered from your local Fire Magic dealer.

Note: For infrared burner equipped grills, see detailed instructions included in your owner's manual.

*** The burner ports and carry-over slots must be kept clean to ensure proper ignition and operation.**

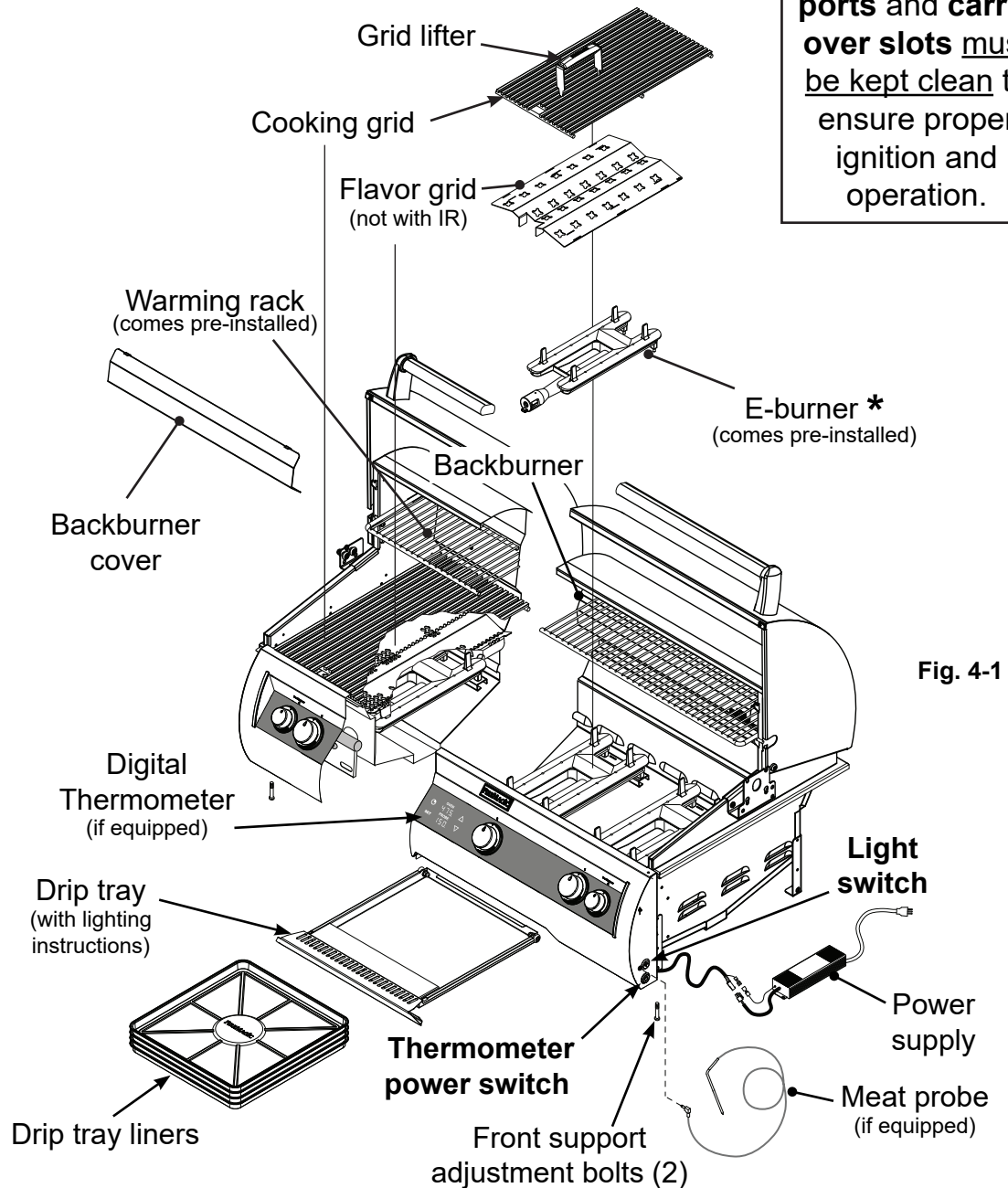

5-Test

Note: This unit must be connected to 120VAC power for electronic lighting.

1. Open lid(s) or remove cover(s) from burner(s) to be lit.
2. Turn all gas control knob(s) to their **OFF** position(s).
3. Turn on the gas at its source.

Note: DO NOT turn on more than one valve at a time for either electronic or manual lighting.

4. Depress the desired control knob **for 5 seconds**. Ensure the igniter is glowing (inside of lighting tube), then, while pressing turn it counterclockwise to the **HI LIGHT** position. Once the burner lights, release the knob.

CAUTION: If a burner does not light within five (5) seconds of turning on the control knob, depress the knob and turn it to the **OFF** position. **WAIT FIVE (5) MINUTES** before repeating step 4. If you smell gas, follow the instructions on the cover of the grill owner's manual. If the burners still do not light after several attempts, refer to the grill owner's manual for manual lighting.

5. Repeat step 4 for each additional burner to be lit.

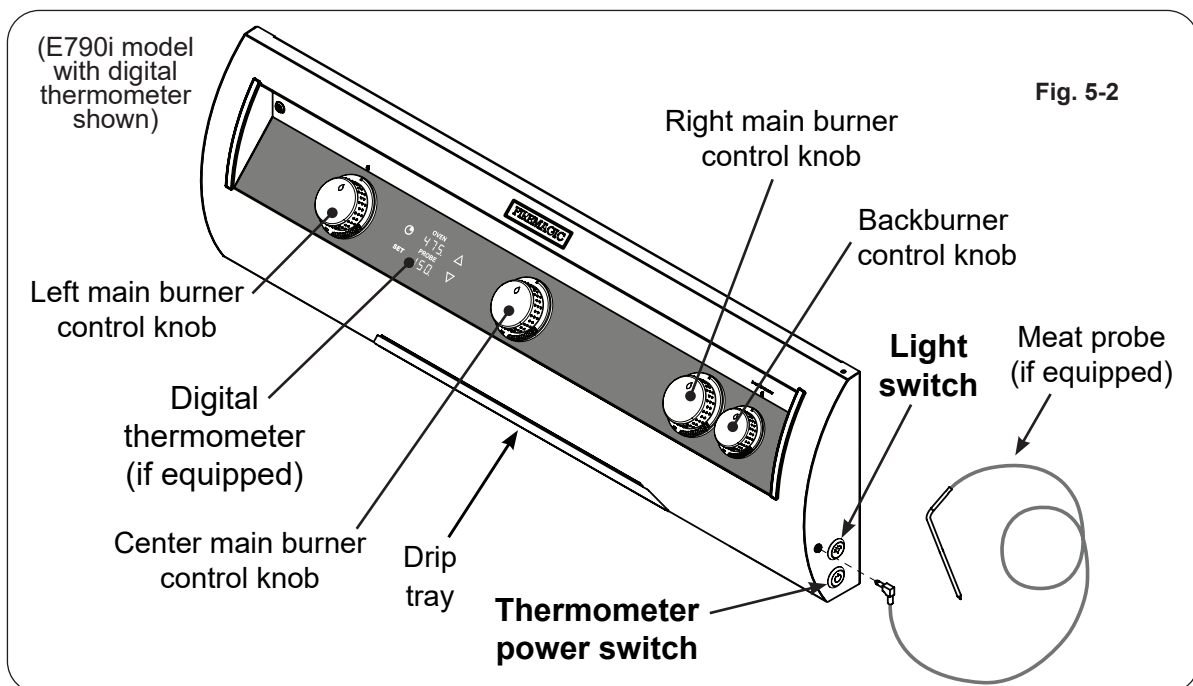
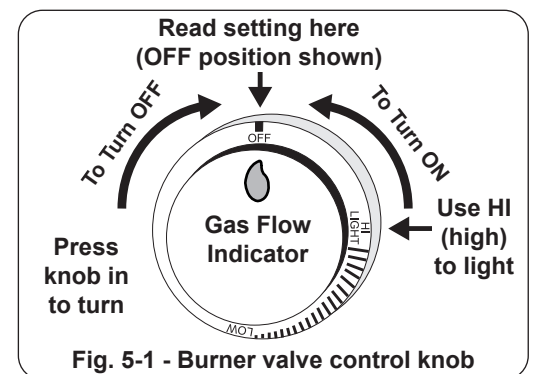

For your convenience and safety; when the control knob is turned to the ON position, the gas flow indicator will change from blue to red. (Red indicates gas flow.) See Fig. 5-1.

WHEN OPERATING THIS GAS APPLIANCE, ALL INSTRUCTIONS AND WARNINGS MUST BE OBSERVED. FAILURE TO DO SO MAY RESULT IN A FIRE OR EXPLOSION CAUSING PROPERTY DAMAGE, BODILY INJURY, OR DEATH.

6-Propane and Natural Gas Safety

FOR PROPANE CONFIGURATIONS; READ ALL SAFETY INSTRUCTIONS AND WARNINGS REGARDING THE USE OF PROPANE GAS FOUND IN YOUR OWNER'S MANUAL. FOR NATURAL GAS READ ALL SAFETY INSTRUCTIONS AND WARNINGS FOUND IN YOUR OWNER'S MANUAL.

7-Routine Maintenance

Your grill must be serviced and maintained properly to ensure optimal performance, appearance, and safety. Clean you grill before and after each use. Additionally, a deep clean of the entire grill and all its components MUST be performed twice a year (or as needed depending on use). See owner's manual for details.