



BUILT-IN OUTDOOR GAS GRILLS

24, 30, 36
"L" & "T" Series

INSTALLATION AND OWNER'S MANUAL

INSTALLER: Leave these instructions with consumer.
CONSUMER: Retain for future reference.



30" L-Series
shown

IMPORTANT: READ THESE INSTRUCTIONS CAREFULLY BEFORE STARTING INSTALLATION OR USE.

WARNINGS AND SAFETY CODES

ONLY TO BE USED OUTDOORS

CODE AND SUPPLY REQUIREMENTS: Installation must conform with local codes or, in the absence of local codes, with either the *National Fuel Gas Code*, ANSI 2223.1/NFPA 54, or the *Natural Gas and Propane Installation Code*, CSA B149.1, or the *Propane Storage and Handling Code*, CSA B149.2, as applicable.

The outdoor cooking gas appliance and its individual shut-off valve must be disconnected from the gas supply piping system during any pressure testing of that system at test pressures in excess of 1/2 psi (3.5 kPa).

The outdoor cooking gas appliance must be isolated from the gas supply piping system by closing its individual manual shut-off valve during any pressure testing of the gas supply piping system at test pressures equal to or less than 1/2 psi (3.5 kPa).

This appliance is designed as an attended appliance. DO NOT leave this appliance burning when unattended.

If an external electrical source is utilized, the outdoor cooking gas appliance, when installed, must be electrically grounded in accordance with local codes or, in the absence of local codes, with the *National Electrical Code*, ANSI/NFPA 70, or the *Canadian Electrical Code*, Part I, CSA C22.1.

Keep any electrical supply cord and the fuel supply hose away from any heated surfaces.



Certified to: ANSI Z21.58
CSA 1.6

⚠ DANGER:

IF YOU SMELL GAS:

- Shut off gas to the appliance.
- Extinguish any open flame.
- Open lid.
- If odour continues, keep away from the appliance and **immediately** call your gas supplier or the fire department.

⚠ WARNING:

- Do not store or use gasoline or other flammable liquids or vapours in the vicinity of this or any other appliance.
- An LP cylinder not connected for use shall not be stored in the vicinity of this or any other appliance.

⚠ WARNING:

Improper installation, adjustment, alteration, service, or maintenance can cause injury or property damage. For proper installation, refer to the installation instructions. For assistance or additional information, consult a qualified professional service technician, service agency, or the gas supplier.

Proper operation of your grill requires prompt and periodic maintenance. See the **SERVICING AND CLEANING section for details.**

Cooking Grid U.S. Patent Nos.
D857,453 D862,984



BUILT-IN OUTDOOR GAS GRILLS

24, 30, 36

Séries "L" et "T"

INSTALLATION ET LE MANUEL DU PROPRIÉTAIRE

INSTALLATEUR: laissez ces instructions au consommateur.
CONSOMMATEUR: À conserver pour référence future.



30" Série "L"
illustrée

IMPORTANT: LIRE ATTENTIVEMENT CES INSTRUCTIONS AVANT DE COMMENCER L'INSTALLATION OU L'UTILISATION.

AVERTISSEMENTS ET CODES DE SÉCURITÉ

À UTILISER UNIQUEMENT À L'EXTÉRIEUR
EXIGENCES EN MATIÈRE DE CODE ET D'APPROVISIONNEMENT: L'installation doit être conforme aux codes locaux ou, en l'absence de codes locaux, soit au *National Fuel Gas Code*, ANSI 2223.1/ NFPA 54, soit au *Natural Gas and Propane Installation Code*, CSA B149.1, soit au *Code de stockage et de manipulation du propane*, CSA B149.2, selon le cas.

L'appareil de cuisson au gaz extérieur et son robinet d'arrêt individuel doivent être déconnectés du système de tuyauterie d'alimentation en gaz pendant tout essai de pression de ce système à des pressions d'essai supérieures à 1/2 psi (3,5 kPa).

L'appareil de cuisson au gaz extérieur doit être isolé du système de tuyauterie d'alimentation en gaz en fermant son robinet d'arrêt manuel individuel pendant tout test de pression du système de tuyauterie d'alimentation en gaz à des pressions d'essai égales ou inférieures à 1/2 psi (3,5 kPa).

**Cet appareil est conçu comme un appareil surveillé.
NE PAS laisser cet appareil brûler sans surveillance.**

Si une source électrique externe est utilisée, l'appareil à gaz de cuisson extérieur, lorsqu'il est installé, doit être mis à la terre conformément aux codes locaux ou, en l'absence de codes locaux, avec le *National Electrical Code*, ANSI/NFPA 70, ou le *Canadian Electrical Code*, Code, Partie I, CSAC22.1. Gardez tout cordon d'alimentation électrique et le tuyau d'alimentation en carburant à l'écart de toute surface chauffée.



Certifié à : ANSI Z21.58
CSA 1.6

⚠ DANGER:

SI VOUS SENTEZ DU GAZ:

- Coupez le gaz de l'appareil.
- Éteignez toute flamme nue.
- Ouvrez le couvercle.
- Si l'odeur persiste, éloignez-vous de l'appareil et appelez **immédiatement** votre fournisseur de gaz ou les pompiers.

⚠ ATTENTION:

- N'entrez pas et n'utilisez pas d'essence ou d'autres liquides ou vapeurs inflammables à proximité de cet appareil ou de tout autre appareil.
- Une bouteille de GPL non connectée pour utilisation ne doit pas être stockée à proximité de cet appareil ou de tout autre appareil.

⚠ ATTENTION:

Une installation, un réglage, une modification, un entretien ou une maintenance inappropriés peuvent causer des blessures ou des dommages matériels. Pour une installation correcte, reportez-vous aux instructions d'installation. Pour obtenir de l'aide ou des informations supplémentaires, consultez un technicien de service professionnel qualifié, une agence de service ou le fournisseur de gaz.

**Le bon fonctionnement de votre
gril nécessite un entretien rapide et
périodique. Voir la section ENTRETIEN
ET NETTOYAGE pour plus de détails.**

Grille de cuisson US Numéros de brevet
D857,453 D862,984

TABLE OF CONTENTS

GETTING STARTED

WARNINGS AND SAFETY CODES	1
INSTALLATION, OPERATION, AND SAFETY INFORMATION.....	5
<i>ELECTRICAL CONNECTIONS (If equipped)</i>	5
GAS SAFETY INFORMATION.....	6
<i>WHEN USING PROPANE GAS</i>	6
<i>WHEN USING NATURAL GAS</i>	6
<i>INSTALLATION SAFETY GUIDELINES</i>	6
OPERATING THE UNIT SAFELY AND CORRECTLY	6
SAFE USE & MAINTENANCE OF PROPANE GAS CYLINDERS	7
ENCLOSURE REQUIREMENTS.....	11
<i>ENCLOSURE PARAMETERS</i>	11
<i>VENTILATION</i>	12
INSTALLATION REQUIREMENTS	17
<i>EXHAUST HOOD</i>	17
<i>CLEARANCES</i>	18
<i>FRONT PANEL CLEARANCES</i>	20
<i>GAS-SUPPLY PLUMBING REQUIREMENTS</i>	20
DIAGRAMMATICAL REPRESENTATIONS OF OUTDOOR AREAS	21
ELECTRICAL SAFETY	22
MODEL SPECIFICATIONS	23
<i>BUILT-IN L-SERIES GRILL WIRING DIAGRAM</i>	24
AOG GRILL REPLACEMENT PARTS LIST	25

INSTALLATION

INSTALLATION.....	27
<i>BUILD / CONSTRUCT ENCLOSURE</i>	27
<i>INSTALL INSULATING LINER (if applicable)</i>	27
<i>SLIDE UNIT INTO ENCLOSURE CUTOUT</i>	27
<i>CONNECT GAS SUPPLY</i>	28
<i>LEAK TEST</i>	29
<i>INSTALL VAPORIZER PANELS</i>	29
<i>INSTALL COOKING GRIDS</i>	29
<i>INSTALL DRIP TRAY</i>	29
OPERATION TEST.....	30

USE, CARE, & SERVICE

IDENTIFICATION OF GRILL CONTROLS	31
USING THE APPLIANCE	32
LIGHTING (IGNITION) INSTRUCTIONS	33
<i>ELECTRONIC LIGHTING</i>	33
<i>MANUAL LIGHTING</i>	33
<i>SETTING THE TIMER (IF APPLICABLE)</i>	33
<i>SHUTTING OFF THE UNIT</i>	33
ROTISSERIE INSTRUCTIONS (IF EQUIPPED)	35
LED LIGHT REMOTE OPERATION	36
<i>REMOTE OPERATION</i>	36
<i>BATTERY</i>	36
SERVICING AND CLEANING	37
<i>CLEANING YOUR GRILL</i>	37
<i>REPLACING HALOGEN BULBS</i>	39
<i>FRONT FACE PANEL REMOVAL</i>	40
<i>SYSTEM RESET</i>	41
<i>MAIN BURNER REMOVAL</i>	41
<i>CONVERT GAS TYPE / CHECK BURNER ORIFICES</i>	42
<i>AIR SHUTTER ADJUSTMENT / BURNER FLAME INSPECTION</i>	44
<i>VALVE "LOW" SETTING ADJUSTMENT</i>	45
<i>CONTROL KNOB FITMENT ADJUSTMENT</i>	45
NOTES PAGE	46
TROUBLESHOOTING.....	47
WARRANTY	48

IMPORTANT NOTICE:

T-Series grills are not equipped with lighting and do not require electrical connections.

All information in this manual regarding electrical power, wiring, or lighting applies exclusively to L-Series grills and is not applicable to T-Series models.

AVERTISSEMENTS

Avertissements généraux :

- Cet appareil est destiné à une utilisation en extérieur uniquement. Si l'appareil est entreposé à l'intérieur, retirez les bouteilles et gardez-les à l'extérieur.
- Ne couvrez pas immédiatement l'appareil après utilisation. Laissez-le refroidir avant de le couvrir, de le déplacer ou de le ranger. Ne pas respecter cette mesure de sécurité pourrait entraîner un incendie causant des dommages matériels, des blessures ou la mort.
- Ne pas utiliser cet appareil sous une surface combustible.
- Ne pas utiliser cet appareil sous un auvent. Le non respect de cette mesure de sécurité pourrait entraîner un incendie ou des blessures.
- Tous les dégagements minimaux détaillés dans la section INSTALLATION REQUIREMENTS DOIVENT être respectés.
- Un régulateur de pression de gaz doit être utilisé avec cet appareil de cuisson à gaz pour l'extérieur. Ce régulateur doit être réglé pour une pression de sortie de 5 pouces colonne d'eau pour le gaz naturel et de 10 pouces pour le propane. Veuillez consulter la liste des pièces de ce manuel du propriétaire pour vérifier si un régulateur est inclus avec votre appareil.
- LE RÉGULATEUR DOIT ÊTRE ÉVALUÉ POUR UN MAXIMUM DE 1/2 (LIVRES PAR POUCE CARRÉS). Veuillez consulter la liste des pièces de ce manuel du propriétaire pour vérifier si un régulateur est inclus avec votre appareil. SI VOTRE OFFRE DE GAZ EST SUPÉRIEURE DE 1/2 (LIVRES PAR POUCE CARRÉS), UN RÉGULATEUR ADDITIONNEL DOIT ÊTRE INSTALLÉ AVANT L'UTILISATION DE L'APPAREIL. VEUILLEZ CONSULTER LA SECTION DES CONDITIONS D'ALIMENTATION EN GAZ POUR LA PRESSION APPROPRIÉE DE L'ALIMENTATION EN GAZ.
- Ne couvrez jamais la surface entière de cuisine ou de gril de gauffreuses ou de casseroles. La surchauffe se produira et les brûleurs ne seront pas très performants quand la chaleur de combustion est emprisonnée au-dessous de la surface à cuire.
- Ne jamais pulvériser d'eau sur une unité de gaz chaude, car cela peut endommager les surfaces ou les composants.

Avertissements de propane :

- Une fuite de GPL peut causer un incendie ou une explosion si enflammée entraînant des blessures corporelles graves ou la mort.
- Communiquez avec le fournisseur de GPL pour les réparations ou pour disposer de la bouteille ou du GPL non utilisé.

INSTALLATION, OPERATION, AND SAFETY INFORMATION

1. Wear gloves and use extreme caution whenever installing and handling this product and its accessories as certain components have sharp edges that can cause personal injury.
2. The outdoor appliance and surrounding area **MUST** remain clear of flammable substances such as gasoline, yard debris, wood, etc. Maintain a minimum horizontal clearance of 18" (in all directions) from combustible materials/items.
3. Do not block the front air inlet along the bottom of the front face panel. See the COMBUSTION AIR AND COOLING AIRFLOW section under INSTALLATION REQUIREMENTS for details.
4. **This unit must be installed so that the required vent openings and surrounding area of the enclosure remain clear and free at all times. See the ENCLOSURE REQUIREMENTS section for details.**
5. When using propane gas: the propane cylinder, regulator, and rubber hose must be in a location not subject to temperatures above 125° F (51° C).
6. The back burner cover (if equipped) must be removed before using the burner.
7. Before each use, ensure the flames on each burner burn evenly along the entire burner with a steady flame (mostly blue). If burner flames are not normal, check and clean the orifice and burner/venturi tubes for insects and insect nests. A clogged tube can lead to a fire beneath the unit. A proper flame pattern will ensure safe operation and optimal performance. Adjust the air shutter as needed to achieve proper flame pattern (see AIR SHUTTER ADJUSTMENT/BURNER FLAME INSPECTION section, under SERVICING AND CLEANING for details).
8. The in-line gas valve or gas cylinder valve must always be shut OFF when the unit is not in use.
9. If applicable: Whenever reconnecting any wires, apply a small amount of dielectric grease to the male connector, then make the connection. This will ensure conductivity and prevent moisture from affecting the contact.
10. **Adults MUST be present when this gas appliance is operating. This appliance MUST NOT be left burning when unattended.**
11. Do not store combustible materials in the enclosure directly beneath the appliance.

WARNING

NEVER cover slots, holes, or passages in the oven bottom or cover an entire rack with material such as aluminum foil. Doing so blocks air flow through the oven and may cause carbon monoxide poisoning.

Aluminum foil linings may trap heat causing a fire hazard.

CAUTION: **FOR YOUR SAFETY, you must provide openings in the enclosure for replacement air and ventilation (in case of possible leakage from gas connections or propane cylinders). Failure to do so may result in a fire or explosion causing property damage, bodily injury, or death. See the ENCLOSURE REQUIREMENTS section for details.**

IMPORTANT: IN THE EVENT OF A GREASE FIRE, IMMEDIATELY SHUT OFF THE MAIN GAS VALVE TO THE UNIT. KEEP THE LID OPEN AND ALLOW THE FIRE TO EXTINGUISH ITSELF. KEEP AT A SAFE DISTANCE. A THOROUGH INSPECTION BY A QUALIFIED PROFESSIONAL SERVICE TECHNICIAN SHOULD BE CONDUCTED BEFORE FUTURE USE OF YOUR UNIT. THE SERVICE TECHNICIAN WILL CHECK THE SYSTEM FOR GAS LEAKS AND WILL CHECK ALL ELECTRICAL WIRING FOR DAMAGE. ALL GAS LEAKS AND WIRING MUST BE REPAIRED PRIOR TO FUTURE USE.

WARNING: NEVER cover more than 75% of the cooking or grill surface with griddles, pots, or pans. Overheating will occur, and burners will not perform properly when combustion heat is trapped below the cooking surface.

The unit serial number tag can be found affixed to the left side of the grill body above the front leg (on an aluminum tag) and on the underside of the drip tray handle (on a thermal label). It is recommended that the drip tray first be removed and cleaned / emptied of its contents, then turned over to view. The unit rating label is located on the manifold channel behind the front face panel.

ELECTRICAL CONNECTIONS (If equipped)

A 120VAC (15 AMP minimum) GFCI GROUNDED three-wire receptacle (not included) is required within the vicinity of the unit to provide power to it. The GFCI receptacle must be a WEATHER-PROOF IN-USE COVERED RECEPTACLE.

- **Observe the National Electric Code and all local codes.**
- **Verify proper polarity of the receptacle.**
- **If an extension cord is used, ensure it is a three-wire GROUNDED cord that is rated for the power of the equipment, and is approved for outdoor use with a W-A marking. DO NOT use two-prong adapters.**
- **DO NOT TAMPER WITH THE EXTENSION CORD OR THE UNIT POWER-SUPPLY CORD.**

Important: ONLY REPLACE THE INTERIOR OVEN LIGHTS WITH 12V / 10 WATT HALOGEN BULB(S).

GAS SAFETY INFORMATION

WHEN OPERATING THIS GAS APPLIANCE, ALL INSTRUCTIONS AND WARNINGS MUST BE OBSERVED. FAILURE TO DO SO MAY RESULT IN A FIRE OR EXPLOSION CAUSING PROPERTY DAMAGE, BODILY INJURY, OR DEATH.

WARNING

This gas appliance and its enclosure **MUST** be plumbed and vented in accordance with local building and safety codes and should be approved by local code enforcement officials. This appliance **MUST** be installed and operated according to the information below.

FAILURE TO PROPERLY VENT THE ENCLOSURE MAY RESULT IN A FIRE OR EXPLOSION CAUSING PROPERTY DAMAGE, BODILY INJURY, OR DEATH.

A leaking gas connection or valve unintentionally left open will create a hazard.

WHEN USING PROPANE GAS

- **Propane gas** (also known as **L.P. gas**) is heavier than air and will accumulate or pool in an inadequately vented enclosure or recessed area.
- If a pool of **propane gas** is ignited, an explosion will occur. Adequate venting at the floor level, or the lowest point where gas could accumulate, will eliminate this danger.
Refer to the **ENCLOSURE REQUIREMENTS** section.
Observe all local codes.
- DO NOT store a spare propane-gas cylinder under or near the enclosure.

WHEN USING NATURAL GAS

- **Natural gas** is lighter than air and will accumulate at the top of an inadequately vented enclosure.
- If an accumulation of **natural gas** is ignited, an explosion will occur. Adequate venting at the top of the enclosure, or the highest point where gas could accumulate, will eliminate this danger.
Refer to the **ENCLOSURE REQUIREMENTS** section.
Observe all local codes.

INSTALLATION SAFETY GUIDELINES

THIS UNIT MUST BE INSTALLED SO THAT THE REQUIRED VENT OPENINGS AND SURROUNDING AREA OF THE ENCLOSURE REMAIN CLEAR AND FREE AT ALL TIMES. See the ENCLOSURE REQUIREMENTS section for details.

CAUTION: FOR YOUR SAFETY, you must provide openings in the enclosure for replacement air and ventilation (in case of possible leakage from gas connections or propane cylinders). Failure to do so may result in a fire or explosion causing property damage, bodily injury, or death. See the ENCLOSURE REQUIREMENTS section for details.

The gas cylinder, regulator, and rubber hose must be in a location not subject to temperatures above 125° F (51° C).

IF A PROPANE CYLINDER IS INSTALLED INSIDE OF THE ENCLOSURE, THE GUIDELINES FOUND IN THE **ENCLOSURE REQUIREMENTS** SECTION MUST BE FOLLOWED.

OPERATING THE UNIT SAFELY AND CORRECTLY

Every time you use the unit, **make sure that:**

1. The area around the unit is clear and free from combustible materials, gasoline and flammable vapours and liquids.
2. There is no blockage of the airflow through the vent openings located on the enclosure.
3. The hose is inspected (if applicable). See SAFE USE & MAINTENANCE OF PROPANE-GAS CYLINDERS section.

DO NOT store any combustible materials, gasoline, and any other flammable vapours/liquids in the vicinity of the unit. Provide adequate clearance for servicing and operation.

SAFE USE & MAINTENANCE OF PROPANE GAS CYLINDERS

IMPORTANT FOR YOUR SAFETY

READ AND FOLLOW ALL WARNINGS PROVIDED WITH THE PROPANE-GAS CYLINDER.

When operating this appliance with a propane-gas cylinder, these instructions and warnings **MUST** be observed.
FAILURE TO DO SO MAY RESULT IN A SERIOUS FIRE OR EXPLOSION.

For requirements related to ventilation, L.P. Cylinders, and the enclosure, see the ENCLOSURE REQUIREMENTS section.

CYLINDER/CONNECTOR REQUIREMENTS

- a. Propane-gas cylinders, valves, and hoses must be maintained in good condition and inspected before each use of appliance. They must be replaced if there is any visible damage. If hose is cut or shows excessive abrasion or wear, it must be replaced before using appliance (see e.).
- b. This unit, when used with a cylinder, should be connected to a standard 5-gallon (20 lb.) propane-gas cylinder equipped with a listed overfilling prevention device. The device has been required on all cylinders sold since October 1, 1998, to prevent overfilling.
- c. Cylinder dimensions should be approximately 12" (30.5 cm) in diameter and 18" (45.7 cm) high. Cylinders must be constructed and marked in accordance with the U.S. Department of Transportation (D.O.T.) *Specifications for LP-Gas Cylinders*, or the Standard for *Cylinders, Spheres, and Tubes for Transportation of Dangerous Goods and Commission*, CAN/CSA-B339, as applicable.
- d. The cylinder used must include a collar to protect the cylinder valve. The cylinder supply system must be arranged for vapour withdrawal. See Fig. 7-1.
- e. When used with a cylinder, the gas supply system must be used with a pressure regulator. The pressure regulator and hose assembly (**not supplied**) used must match the specification for Type I by ANSI Z 21.58/CGA 1.6 and must comply with UL 144 as a part of the self-contained LP gas supply system (see Fig. 7-1).
- f. The propane-gas cylinder valve must be equipped with a cylinder connection device, described as Type I in the standard defined in paragraph e. above. This device is commonly described as an Acme thread coupler.
- g. If the cylinder comes with a dust plug, place it on the cylinder valve outlet whenever the cylinder is not in use. Only install the type of dust cap on the cylinder valve outlet that is provided with the cylinder valve. Other types of caps or plugs may result in leakage of propane.

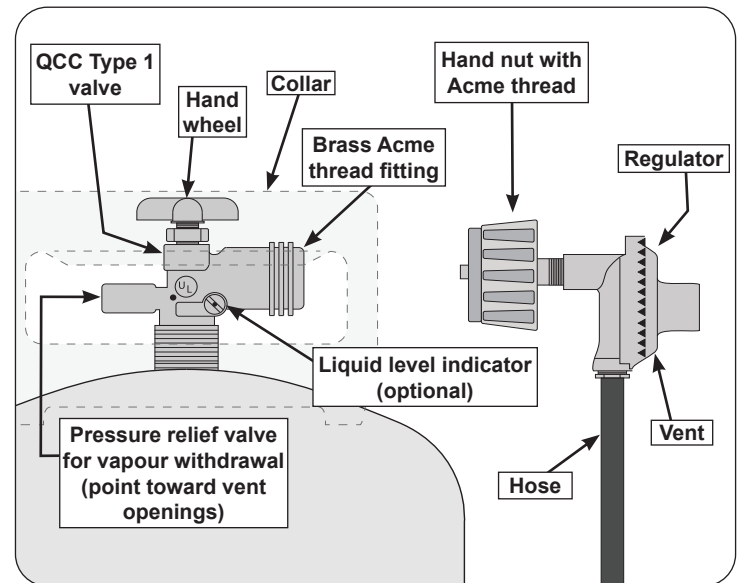

Fig. 7-1 Type I Acme thread coupler

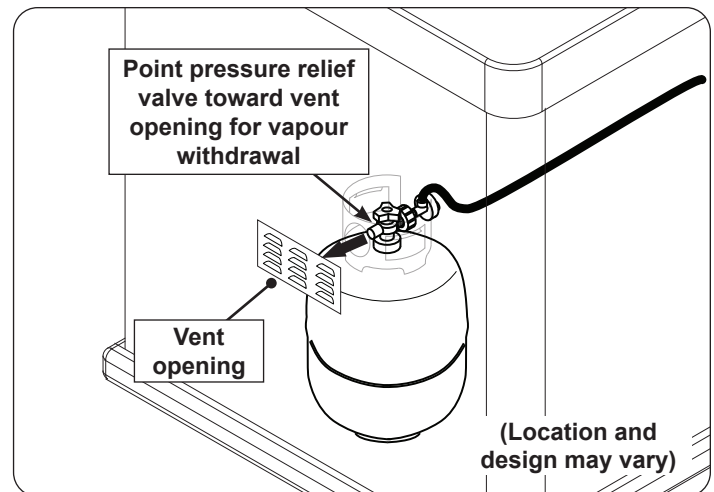

Fig. 7-2 Vapour withdrawal detail

COUPLER OPERATION

To connect the regulator/hose assembly to the propane-gas cylinder valve fitting: Press the hand nut on the regulator over the Acme thread fitting on the cylinder valve. Turn the hand nut clockwise to engage the threads and tighten until snug. The use of pliers or a wrench should not be necessary. Only cylinders marked "propane" may be used.

To disconnect: Turn the hand nut counterclockwise until detached (Fig. 7-1).

UTILISATION SÛRE ET ENTRETIEN DES CYLINDRES DE GAZ DE PROPANE

IMPORTANT POUR VOTRE SÛRETÉ

LISEZ ET SUIVEZ TOUS LES AVERTISSEMENTS ÉQUIPÉS DE VOTRE CYLINDRE DE GAZ DE PROPANE.

En actionnant cet appareil avec un cylindre de gaz de propane ON DOIT observer ces instructions et avertissements.

LE MANQUE DE FAIRE AINSI PEUT AVOIR COMME CONSÉQUENCE UNE INCENDIE OU UNE EXPLOSION SÉRIEUSE.

Pour les exigences relatives à la ventilation, aux bouteilles de GPL et à l'enceinte, reportez-vous à la section ENCLOSURE REQUIREMENTS.

CYLINDRE ET CONDITIONS ET CARACTÉRISTIQUES DE CONNECTEUR

- Les bouteilles, les vannes et les tuyaux de propane doivent être entretenus et inspectés avant chaque utilisation. Ils doivent être remplacés en cas de dommages visibles. Si le tuyau est coupé ou présente des signes d'abrasion ou d'usure, il doit être remplacé avant utilisation (**voir e.**).
- Cette unité, lorsqu'elle est utilisée avec une bouteille, doit être connectée à une bouteille standard de gaz propane de 5 gallons (20 lb) équipée d'un dispositif anti-débordement répertorié. L'appareil est obligatoire sur toutes les bouteilles vendues depuis le 1er octobre 1998 afin d'empêcher tout remplissage excessif.
- Les dimensions du cylindre doivent être d'environ 12" (30,5 cm) de diamètre et 18" (45,7 cm) de hauteur. Les bouteilles doivent être construites et marquées conformément aux spécifications du ministère des Transports (DOT) pour les bouteilles à gaz LP ou à la norme relative aux bouteilles, sphères et tubes pour le transport des marchandises dangereuses et à la Commission, CAN / CSA-B339, selon le cas.
- La bouteille utilisée doit comporter un collier pour protéger le robinet de la bouteille. Le système d'alimentation de la bouteille doit être conçu pour le retrait de la vapeur. Voir Fig. 8-1.
- Lorsqu'il est utilisé avec une bouteille, le système d'alimentation en gaz doit être utilisé avec un régulateur de pression. Le régulateur de pression et l'ensemble de tuyau (**non fourni**) utilisés doivent correspondre à la spécification de type I par ANSI Z 21.58/CGA 1.6 et doivent être conformes à UL 144 en tant que partie du système d'alimentation en gaz propane autonome (voir Fig. 8-1).
- La valve de cylindre de gaz de propane doit être équipée d'un dispositif d'accouplement de raccordement de cylindre, décrit comme type I dans la norme définie dans le e. de paragraphe ci-dessus. Ce dispositif est généralement décrit comme coupleur de fil de point culminant.
- Si la bouteille est livrée avec un bouchon anti-poussière, placez-le sur la sortie du robinet de la bouteille la chaque fois que la bouteille n'est pas utilisée. Installez uniquement le type de capuchon anti-poussière sur la sortie du robinet de la bouteille qui est fourni avec le robinet de la bouteille. D'autres types de bouchons ou de bouchons peuvent entraîner des fuites de propane.

OPÉRATION DE COUPLEUR

Pour relier le régulateur/hose à l'ajustage de précision de valve de cylindre de gaz de propane: Serrez l'écrou de main sur le régulateur au-dessus de l'ajustage de précision de fil de point culminant sur la valve de cylindre. Tournez l'écrou de main dans le sens des aiguilles d'une montre pour engager les fils et pour serrer jusqu'à ce que douillettement. L'utilisation des pinces ou de la clé ne devrait pas être nécessaire. Seulement le "propane" marqué par cylindres doit être employé.

Pour déconnecter: tournez l'écrou à main dans le sens antihoraire jusqu'à ce qu'il soit détaché (Fig. 8-1)

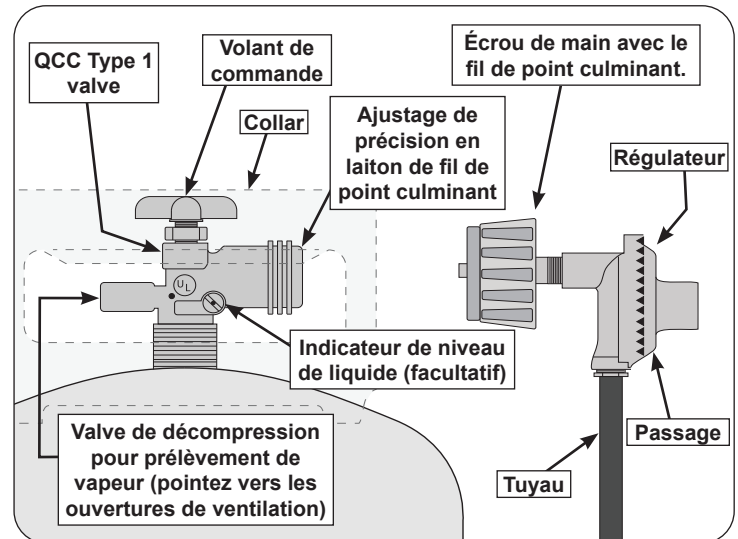

Fig. 8-1 Type coupleur de fil de point culminant d'I

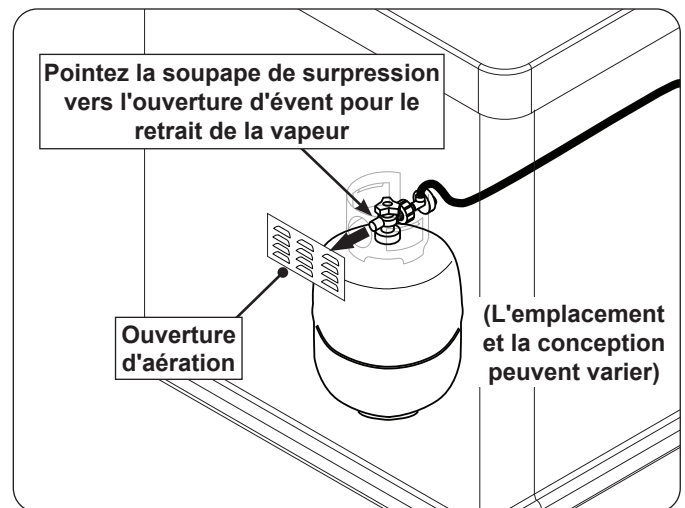

Fig. 8-2 Détail du retrait de vapeur

SAFE USE & MAINTENANCE OF PROPANE GAS CYLINDERS (Cont.)

Important: Before using the unit, and after each time the cylinder is removed and reattached, check the hose for wear (see a.) and check all connections for leaks. Turn off the unit valves and open the main cylinder valve, then check connections with soapy water. **NEVER USE A FLAME TO CHECK FOR LEAKS.** Repair any leaks before lighting the unit.

CAUTION: Always turn the propane cylinder main valve off after each use, and before moving the unit and cylinder or disconnecting the coupling. This valve must remain closed and the cylinder disconnected while the appliance is not in use, even though the gas flow is stopped by a safety feature when the coupler is disconnected.

Carefully inspect the hose assembly each time before the gas is turned on. A cracked or frayed hose must be replaced immediately.

If the appliance is stored indoors, the cylinder must be disconnected and removed. Disconnected cylinders must be stored outdoors, out of the reach of children, with threaded valve plugs tightly installed, and must not be stored in a building, garage, or any other enclosed area.

FOR YOUR SAFETY

- A. DO NOT store a spare propane-gas cylinder under or near this appliance.
- B. NEVER fill the cylinder beyond 80-percent full.
- C. IF THE INFORMATION IN a. AND b. IS NOT FOLLOWED EXACTLY, A FIRE CAUSING DEATH OR SERIOUS INJURY MAY OCCUR.
- D. **CGA 791 connections on LP gas cylinders:** The cylinder face elastomeric face seal element on these devices could, over time, show marked and visible damage or deterioration that might cause a leak even with the connection tightened. A visual inspection for the seal must be carried out every time a LP gas cylinder is replaced or refilled. Any LP gas cylinder showing signs of damage or deterioration as illustrated in Fig. 9-1, including visible cracks and pitting, must be replaced.

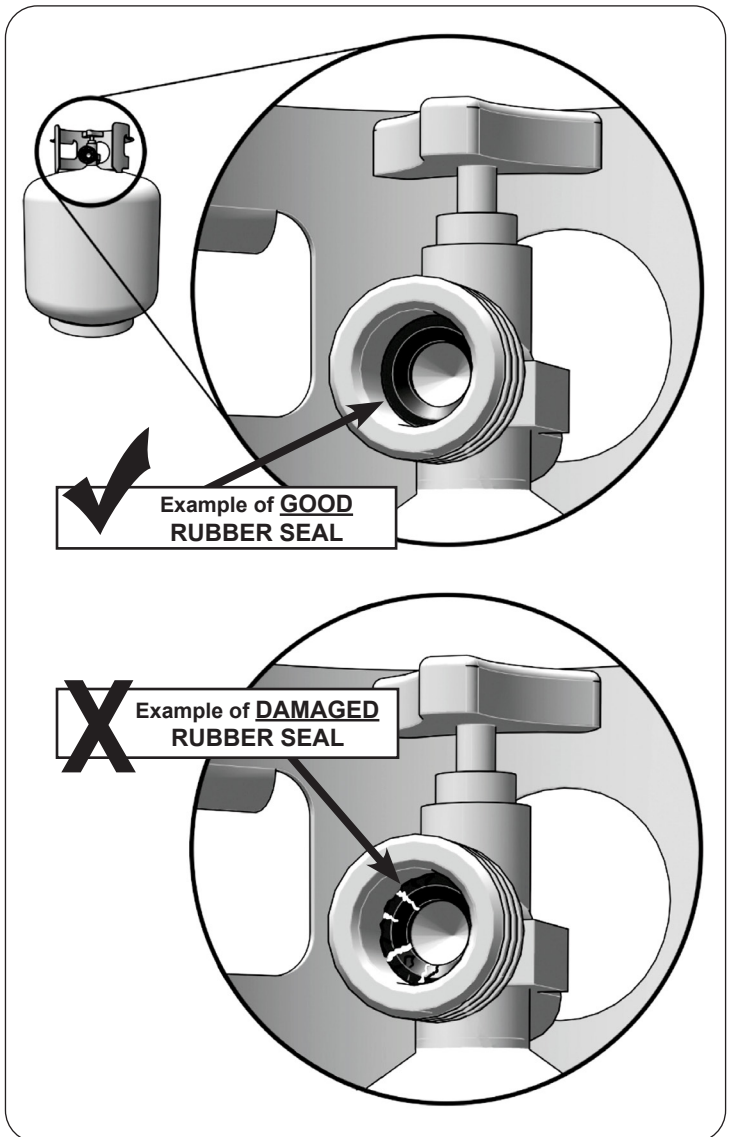

Fig. 9-1 Inspect rubber seal

Important: Avant d'employer le unité, et ensuite chaque fois que le cylindre est enlevé et rattaché, examinez tous les raccords pour détecter les fuites. Arrêtez les valves de unité et ouvrez la valve principale de cylindre, puis vérifiez les raccords avec de l'eau savonneuse. **NE JAMAIS UTILISER UNE FLAMME POUR DÉTECTER DES FUITES.** Réparez toutes les fuites avant d'allumer le unité.

ATTENTION: Tournez toujours la valve principale de cylindre de propane au loin après chaque utilisation, et avant de déplacer le unité et le cylindre, ou débrancher l'accouplement. Cette valve doit rester fermée et le cylindre a débranché alors que l'appareil n'est pas en service, quoique l'écoulement de gaz soit arrêté par un dispositif de sûreté quand le coupleur est débranché.

Inspectez soigneusement l'ensemble de tuyau chaque fois avant que le gaz soit allumé. Un tuyau fissuré ou effiloché doit être immédiatement remplacé.

Si l'appareil est stocké à l'intérieur, le cylindre doit être disconnected et a enlevé. Des cylindres Disconnected doivent être stockés dehors, hors de la portée des enfants, avec les prises de valve filetées étroitement installées, et ne doivent pas être stockés dans un bâtiment, le garage, ou n'importe quel autre secteur inclus.

POUR VOTRE SÛRETÉ

- a. Ne stockez pas un cylindre de gaz disponible de propane dessous ou ne vous approchez pas de cet appareil.
- b. Ne remplissez jamais cylindre au delà de 80 pour cent de plein.
- c. SI L'INFORMATION DANS "A" ET "B" N'EST PAS SUIVIE EXACTEMENT, UN FEU CAUSANT LA MORT OU DES DOMMAGES SÉRIEUX PEUT SE PRODUIRE.
- d. **Connexions CGA 791 sur les bouteilles de GPL :** l'élément d'étanchéité en élastomère de la face de la bouteille de ces appareils peut, au fil du temps, présenter des dommages ou une détérioration marqués et visibles susceptibles de provoquer une fuite même avec la connexion serrée. Une inspection visuelle du joint doit être effectuée chaque fois qu'une bouteille de GPL est remplacée ou remplie. Toute bouteille de GPL présentant des signes de dommages ou de détérioration, tel qu'illustré à la Fig. 10-1, y compris des fissures et des piqûres visibles, doit être remplacée.

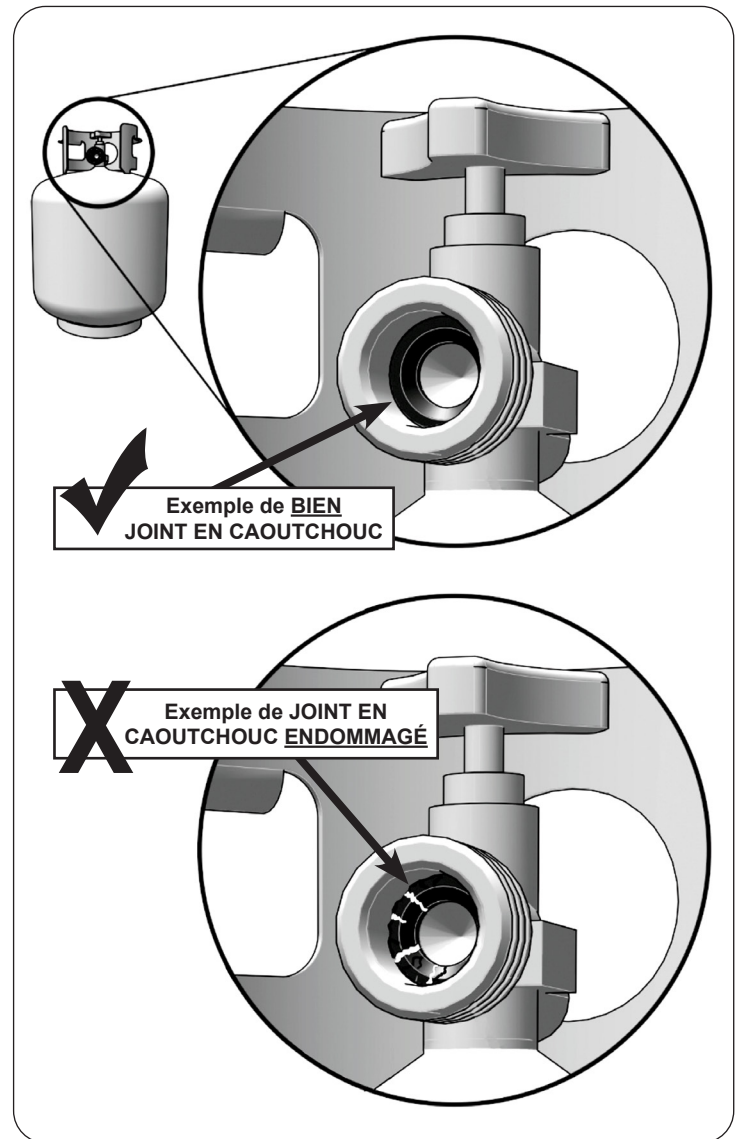

Fig. 10-1 Inspecter le joint en caoutchouc

ENCLOSURE REQUIREMENTS

GFRC islands are available (for select models). They meet all enclosure and ventilation requirements. Contact your local dealer. For requirements regarding custom-built enclosures, see below.

To ensure proper operation and safety, the enclosure **MUST** comply with the following:

- Proper construction and cutout openings - see INSTALLATION REQUIREMENTS and ENCLOSURE PARAMETERS sections.
- Proper ventilation - see VENTILATION section.
- Proper clearances - see INSTALLATION REQUIREMENTS section.

You **MUST** read and follow these sections for complete enclosure requirement details.

ENCLOSURE PARAMETERS

General Guidelines

The enclosure can be constructed according to your individual preference, while following all guidelines found in this manual. **The enclosure MUST (see Fig. 11-1):**

- be installed on a hard and level surface
- be properly vented (see VENTILATION section)
- have a countertop that is non-combustible (enclosure may be combustible construction with proper provision*)
- have the minimum dimensions specified in Fig. 11-1
- have the minimum cutout dimensions (see CUTOUT DIMENSIONS section)
- if equipped, be setup so that the power supply is within reach of a properly wired and inspected **120VAC (15 AMP minimum) Ground Fault Circuit Interrupter (GFCI) GROUNDED three-wire receptacle**
- have access to the interior for ease of installation and service
- be setup so the unit is as close to the vent openings as possible
- be designed so that the grill is supported by the stainless-steel hanger extending from the upper portion of the unit (rests on left, right, and back of the countertop cutout), and the two front support adjustment bolts located below the control panel (left and right sides) - see INSTALLATION section
- have drainage cutouts (if needed) to prevent the accumulation of water within the enclosure
- meet all requirements found in Fig. 11-1 and the following sections

* **When installing this unit in a combustible enclosure, an approved insulating liner MUST be used. Reference Table 3 in the MODEL SPECIFICATIONS section for liner model #.**

When an L.P. cylinder is used in the enclosure, additional requirements exist, see the L.P. CYLINDER REQUIREMENTS section.

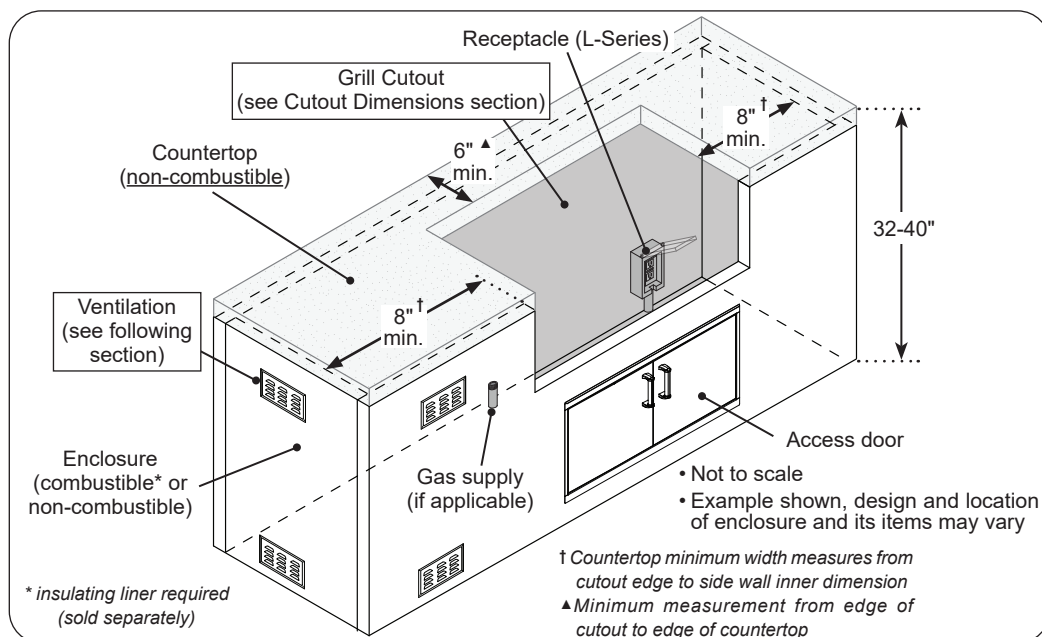

Fig. 11-1 Enclosure specifications

ENCLOSURE REQUIREMENTS (Cont.)

VENTILATION

FOR YOUR SAFETY, you must provide the openings specific to your gas type for replacement air and ventilation of the enclosure (in case of possible leakage from gas connections and L.P. cylinders as applicable, and for heat dissipation). See the following sections for ventilation requirements specific to your gas type. **Failure to provide proper ventilation for your gas type may result in a fire or explosion causing property damage, bodily injury, or death.**

WARNING: Vent openings in side walls shall not communicate directly with other enclosures of the outdoor cooking gas appliance (see Fig. 12-1).

- Ventilation openings shall not be located in front of the appliance above floor level.
- Every opening shall have a minimum dimension so as to permit the entrance of a 3/16" (4.8 mm) rod.
- **The openings must remain unobstructed:**

The clearance between the openings and any items outside of the enclosure is a minimum of 6". The clearance between the openings and any items within the enclosure is a minimum of 2". See Fig. 12-2.

KEEP THE REQUIRED VENT OPENINGS AND SURROUNDING AREA OF THE ENCLOSURE CLEAR AND FREE AT ALL TIMES.

Natural Gas Ventilation Requirements

When natural gas is used in the enclosure, **the guidelines below MUST be followed:**

One side of the enclosure shall be left completely open to the outside; **OR 1 minimum vent opening (at top level) or 2 vent openings (1 at top and 1 at floor level) MUST be created (reference Fig. 12-3):**

- When using only **1 vent opening:** the opening must be at top level and must have a minimum of **20 sq. in.** of free area.
- When using **2 vent openings:** The **top and floor level openings** must have a minimum of **10 sq. in.** of free area each. The openings must be equally sized (ventilation total of 20 sq. in. free area).
- The opening **at the top level** must begin 1" or less below the countertop level and end no more than 5" below the countertop level.
- If applicable, the opening **at the floor level** must begin 1" or less above the floor level and end no more than 5" above the floor level.
- If planning for 2 vent openings, it is acceptable to use RHP venting panels (PN 5510-01). Contact your dealer.

Note: These same requirements apply when multiple appliances exist in the enclosure.

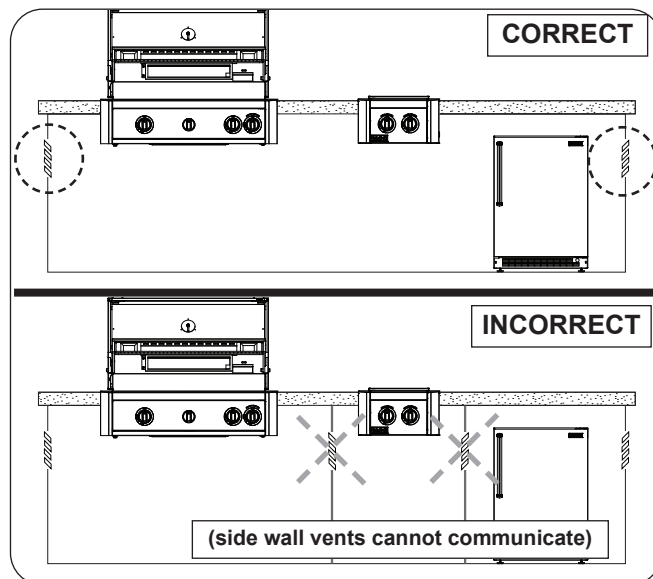

Fig. 12-1 Correct / Incorrect side wall venting

- 6" min. clearance between all vent openings and any items outside of enclosure
- 2" min. clearance between all vent openings and any items within enclosure

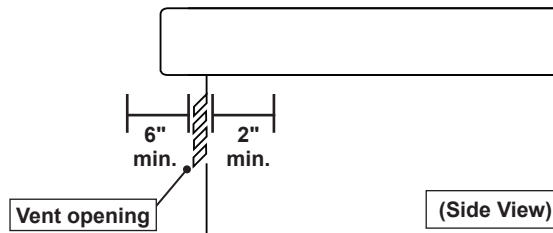

Fig. 12-2 Vent openings clearance

NATURAL GAS VENTILATION REQUIREMENTS:

1 Vent Setup:

- Minimum 1 opening (at top level)
- Top opening: min. 20 sq. in. of free area, within 5" of countertop

2 Vent Setup:

- 2 openings (1 at top & 1 at floor level)
- Top opening: within 5" of countertop (see below)
- Floor opening: within 5" of floor (see below)
- Each vent opening: min. 10 sq. in. of free area
- Total = 20 sq. in. free area

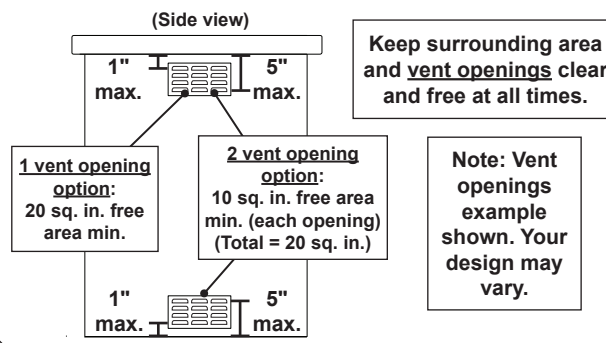

Fig. 12-3 Natural gas ventilation detail

ENCLOSURE REQUIREMENTS (Cont.)

L.P. Cylinder Ventilation Requirements

When an L.P. cylinder is used in the enclosure, the guidelines below MUST be followed:

One side of the enclosure shall be left completely open to the outside; OR 4 minimum vent openings (2 at top and 2 at floor level) MUST be created (reference Fig. 13-1):

- Each opening at the top level must have a minimum of 10 sq. in. of free area. The openings must be equally sized.
- Each opening at the floor level must have a minimum of 5 sq. in. of free area. The openings must be equally sized.
- Ventilation total of 30 sq. in. free area
- Each opening at the top level must be on adjacent walls of the enclosure, and spaced at a minimum of 90 degrees. The openings must begin 1" or less below the countertop level and end no more than 5" below the countertop level.
- Each opening at the floor level must be on adjacent walls of the enclosure, and spaced at a minimum of 90 degrees. The openings must begin 1" or less above the floor level and end no more than 5" above the floor level.
- The above outlined is the minimum ventilation requirement for each L.P. cylinder used within the enclosure.
- For L.P. cylinders larger than 20 lb capacity, there must be a minimum of 1 in²/lb of open area for top vent openings and a minimum of 1/2 in²/lb of open area for bottom vent openings.

Note: These same requirements apply for each individual L.P. cylinder being used within the enclosure.

- **Additional requirements exist for L.P. cylinders, see the L.P. CYLINDER REQUIREMENTS section.**

Remote L.P. Ventilation Requirements

When a remote L.P. gas system is used with the enclosure, the guidelines below MUST be followed:

One side of the enclosure shall be left completely open to the outside; OR 4 minimum vent openings (2 at top and 2 at floor level) MUST be created (reference Fig. 13-2):

- Each opening must have a minimum of 45 sq. in. of free area. The openings must be equally sized.
- Ventilation total of 180 sq. in. free area
- Each opening at the top level must be on adjacent side walls of the enclosure, and spaced at a minimum of 90 degrees. The openings must begin 1" or less below the countertop level and end no more than 5" below the countertop level.
- Each opening at the floor level must be on adjacent walls of the enclosure, and spaced at a minimum of 90 degrees. The openings must begin 1" or less above the floor level and end no more than 5" above the floor level.

Note: These same requirements apply when multiple appliances exist in the enclosure.

L.P. CYLINDER VENTILATION REQUIREMENTS:

- Minimum 4 openings (2 at top & 2 at floor level)
- 2 per adjacent wall - spaced at min. 90 degrees
- Top openings: min. 10 sq. in. of free area each, within 5" of countertop (20 sq. in. top ventilation)
- Floor openings: min. 5 sq. in. of free area each, within 5" of floor (10 sq. in. floor ventilation)
- Total = 30 sq. in. free area

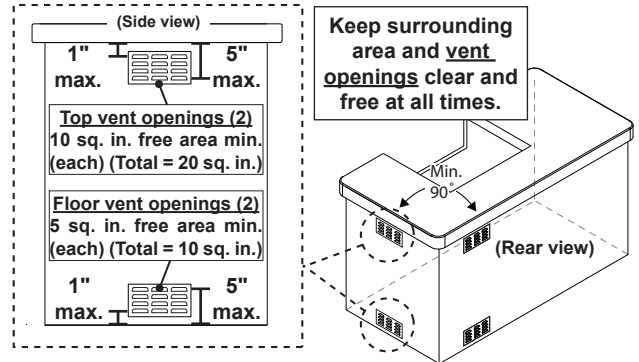

Fig. 13-1 L.P. cylinder ventilation detail

REMOTE LP VENTILATION REQUIREMENTS:

- Minimum 4 openings (2 at top & 2 at floor level)
- 2 per adjacent wall - spaced at min. 90 degrees
- Top openings: within 5" of countertop (see below)
- Floor openings: within 5" of floor (see below)
- Each vent opening: min. 45 sq. in. of free area
- Total = 180 sq. in. free area

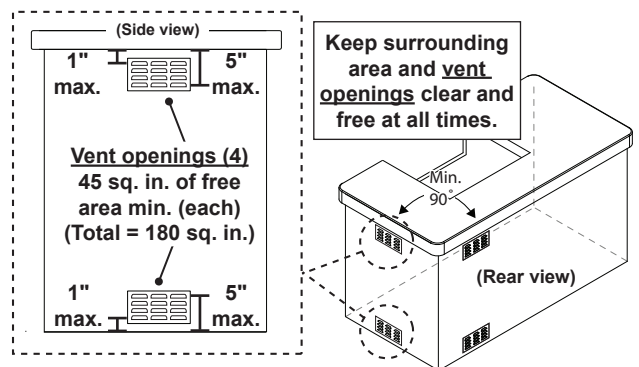

Fig. 13-2 Remote LP ventilation detail

ENCLOSURE REQUIREMENTS (Cont.)

L.P. Cylinder Requirements (if applicable)

When a propane (L.P.) cylinder is installed inside of the enclosure, the additional guidelines below **MUST** be followed. FAILURE TO DO SO MAY CAUSE DAMAGE TO YOUR UNIT AND/OR PERSONAL INJURY. Refer to Fig. 14-1 and 14-2.

- Only a C.S.A. listed stainless-steel flex connector must be connected to the unit.
- The regulator/hose assembly coming from the cylinder must only be connected to the above mentioned flex connector (with regulator). A 1/2" male-to-male flare adapter will be required (not included). **DO NOT connect the regulator/hose assembly directly to the unit.**
- A non-combustible heat shield must be installed to protect the regulator/hose assembly and cylinder valve.
- The cylinder must be properly secured, and rest at least 2" above the ground.
- An additional vent opening is recommended in the access door near the cylinder and at the gas connection level (minimum 10 sq. in. of free area).
- The pressure relief valve on the cylinder must be pointed toward the vent opening for vapour withdrawal.

An "access door with tank tray and louvers" is available. It includes a heat shield that rests directly above the L.P. cylinder, a tray, a retention device, and louvers to meet the cylinder install requirements. The door is shown in Fig. 14-3. Contact your dealer for ordering information.

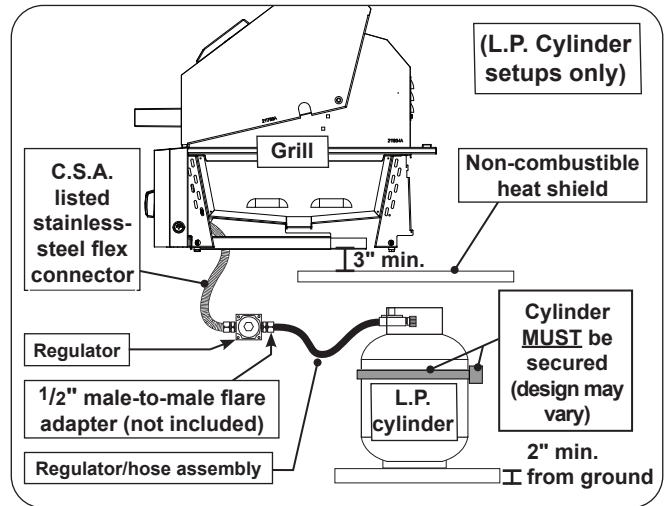

Fig. 14-1 L.P. cylinder orientation (if applicable)

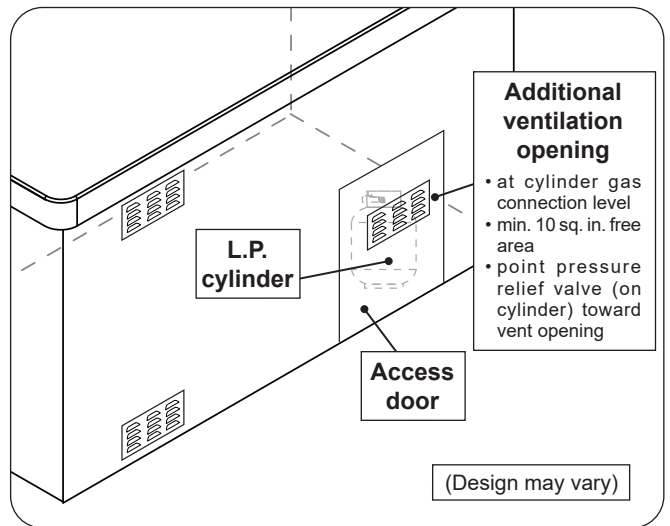

Fig. 14-2 Additional vent opening for L.P. cylinder

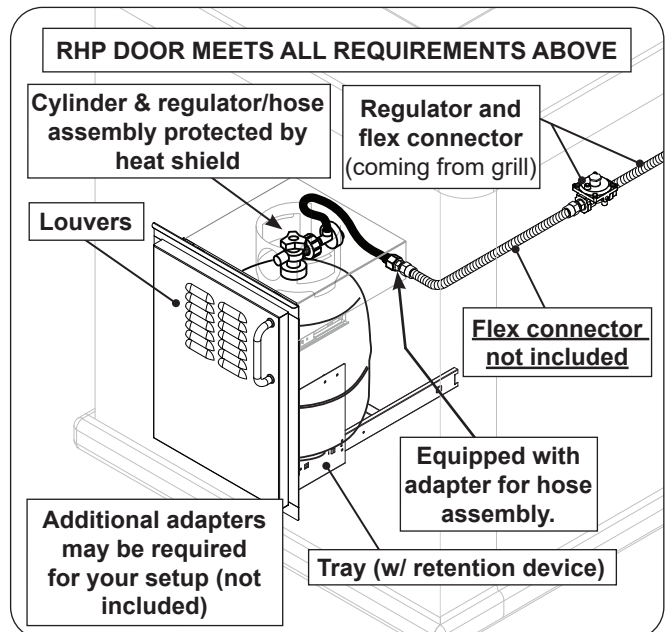

Fig. 14-3 Optional door w/ tank tray & louvers

ENCLOSURE REQUIREMENTS (Cont.)

CUTOUT DIMENSIONS

Important: These cutout dimensions below are for non-combustible enclosures. If installing this grill in a combustible enclosure, the correct insulating liner must be used (and the cutout dimensions will differ). See Table 3. Refer to the instructions supplied with the liner for the correct cutout dimensions.

Description (non-combustible cutouts)	24"	30"	36"
A Countertop to unit bottom cutout	8 1/2"	8 1/2"	8 1/2"
B Side to side cutout	24 1/2"	30 1/2"	36 3/4"
C Front to back cutout *	19 1/2"	19 1/2"	19 1/2"
D Front panel width (overhang) cutout †	28 1/2"	34 1/2"	40 3/4"

* Includes any substrate at front wall of enclosure (in the area the rear of the front panel is to sit flush against). See SUBSTRATE section on next page.

† Only applicable for non-combustible enclosures that have countertops with an overhang (see illustration and section below).

Table 1 - Cutout Dimensions (for non-combustible enclosures)

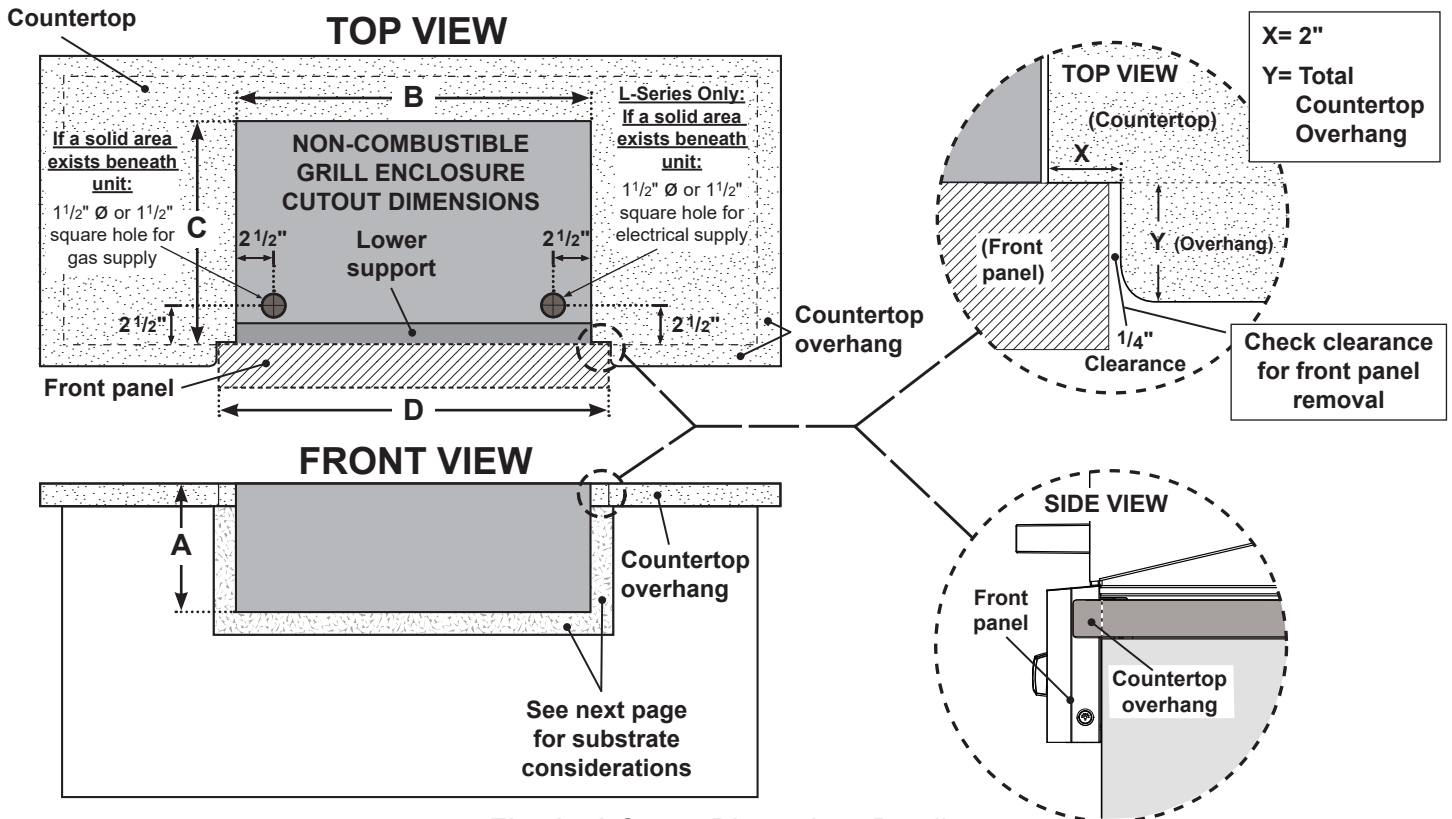

Fig. 15-1 Cutout Dimensions Detail

COUNTERTOP OVERHANG

The front panel is designed to sit flush against the enclosure front wall. If the countertop extends beyond the front wall, creating a countertop overhang, it must be cut flush with the front wall for the width of the front panel or a gap will be created exposing the forward portions of the left and right side grill fire walls. See illustrations in Fig. 15-1 above for the correct setup, and Fig. 15-2 for an incorrect setup.

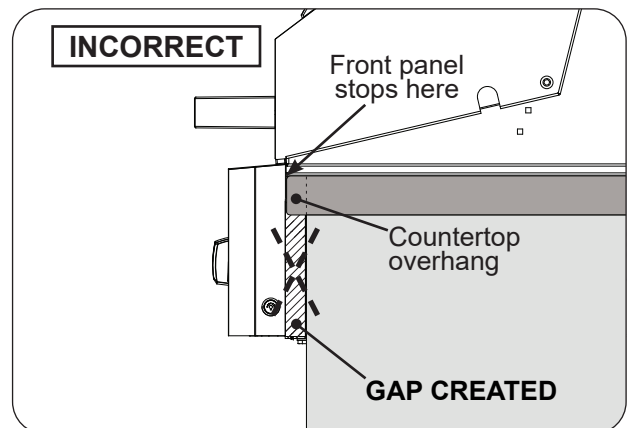

Fig. 15-2

SUBSTRATE

When adding any substrate to the enclosure front wall (including tiles, stone, etc.), consider the following:

Substrate Behind Front Panel

Substrate + countertop "front to back" cutout must equate to **Dim. C** (see previous page) when the substrate sits flush behind the front panel.

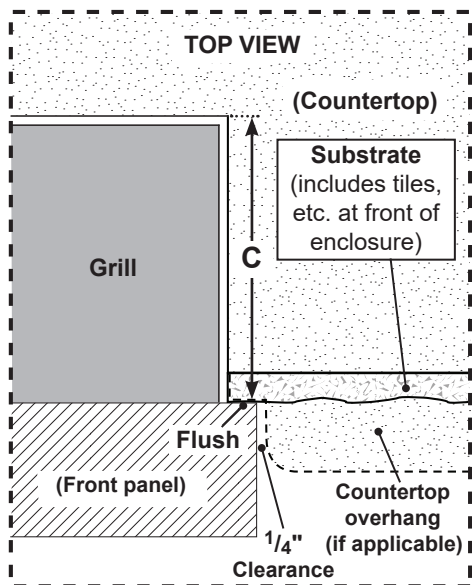

Fig. 16-1

Substrate Alongside Front Panel

Any additional substrate alongside the front panel does not need to be considered in **Dim. C** (see previous page), however a 1/4" clearance on each side (same as overhang) and below is required.

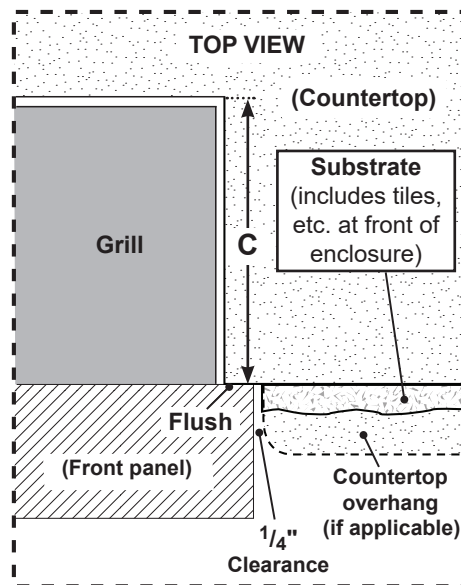

Fig. 16-2

INSTALLATION REQUIREMENTS

Installation must be performed by a qualified professional service technician.

This unit is designed for outdoor use only. **DO NOT** use this unit inside a building, garage, or enclosed area. **DO NOT** install this unit in or on a recreational vehicle or boat.

Any constructed outdoor area in which the appliance is used shall comply with one of the following:

- An outdoor area with walls on three sides, and no overhead cover
- Within a partial outdoor area that includes an overhead cover and no more than two walls. The sidewalls may be parallel, as in a breezeway, or at right angles to each other
- Within a partial outdoor area that includes an overhead cover with walls on three sides, and at least 30% or more of the horizontal periphery of the enclosure that is open and unrestricted

Note: All openings must be permanently open.

Note: Sliding doors, garage doors, windows, or screened openings are not considered as permanent openings.

Refer to DIAGRAMMATICAL REPRESENTATIONS OF OUTDOOR AREAS section.

EXHAUST HOOD

IMPORTANT:

DO NOT use this appliance under combustible overhead construction unless installed in conjunction with a suitable UL 710 or ULC S646 approved heavy duty vent hood only. The vent hood must be placed in operation during operation of the appliance.

When installed under overhead non-combustible construction, an exhaust hood is highly recommended; see exhaust hood information below and Fig. 17-1.

When using an exhaust hood, the area above the cooking surface of the grill must be covered with a hood larger than the cooking area of the grill and with a minimum of 1000 CFM (cubic feet per minute) rated exhaust fan for proper outdoor application.

An AOG vent hood is available to pair with your grill. See Table 3. Contact your dealer.

Clearances

A minimum 5 foot clearance is required between the countertop and the overhead construction. (No combustible materials are allowed within this area.)

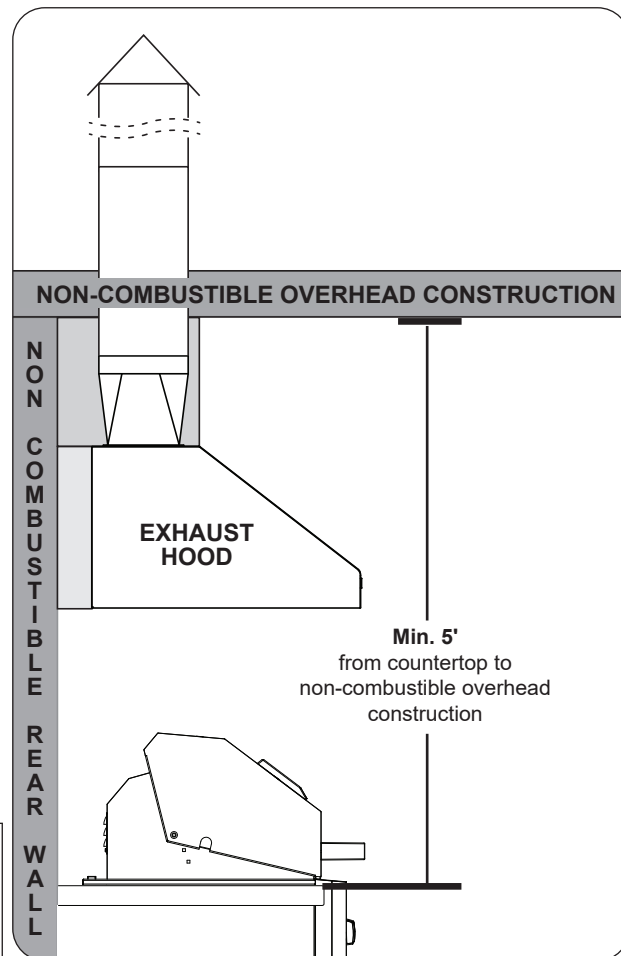

Fig. 17-1 Overhead requirements

INSTALLATION REQUIREMENTS (Cont.)

CLEARANCES

Rear Wall

For the minimum clearances between the unit and rear walls, your setup must fall within one (or more) of the following:

A. Clearance between unit and strictly non-combustible rear wall

(i.e. brick wall, see Fig. 18-1)

- The unit must have a minimum clearance of 4" from the non-combustible rear wall.

(To allow for proper ventilation and prevent dangerous overheating.)

B. Clearance between unit and a protected combustible rear wall

(i.e. a non-combustible wall in front of a combustible wall to serve as a barrier. This can be accomplished by brick, or a metal stud finished with non-combustible substrate, see Fig. 18-2)

- The unit must have a minimum clearance of 12" from the protected combustible rear wall.

(The 4" non-combustible material plus an additional 8" clearance between the unit and protected rear wall.)

C. Clearance between unit and combustible rear wall

- The unit must have a minimum clearance of 15" from the combustible rear wall (see Fig. 18-3).

Backsplash (if applicable)

If a non-combustible backsplash exists, it must have a minimum of a 4" clearance from the rear of the unit (to allow for proper ventilation and prevent dangerous overheating). See Fig. 18-4.

Important: This 4" backsplash clearance must first be met prior to any non-combustible walls beginning behind it.

Clearances continued on the following page

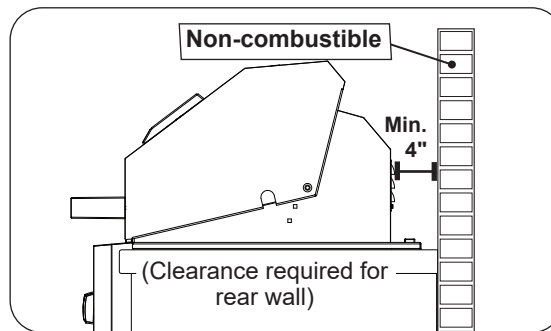

Fig. 18-1 Clearance 'A' Diagram

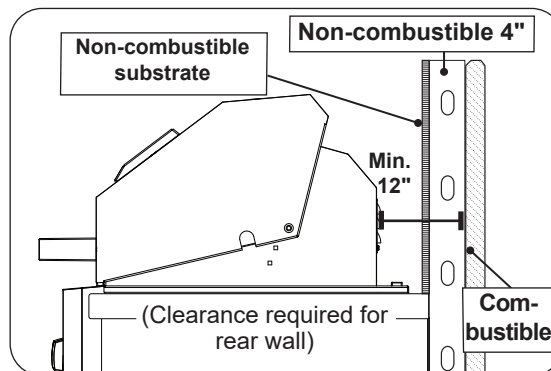

Fig. 18-2 Clearance 'B' Diagram

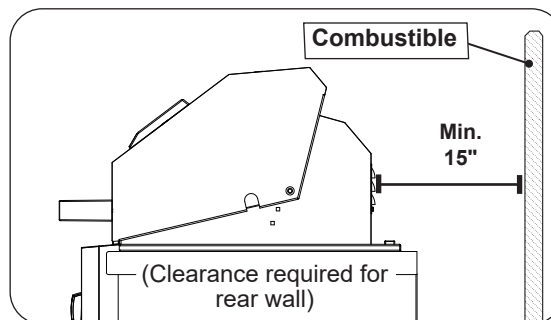

Fig. 18-3 Clearance 'C' Diagram

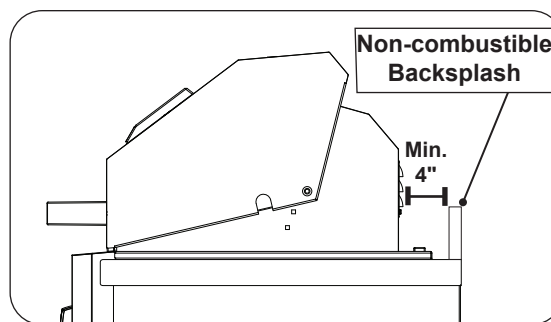

Fig. 18-4 Backsplash clearance

INSTALLATION REQUIREMENTS (Cont.)

Corner Wall (if applicable)

The unit must have a minimum clearance of 24" from any corner walls (to account for variables in airflow that could affect performance). See Fig. 19-1.

Side Wall (if applicable)

The unit must have a minimum clearance of 18" from any side walls. See Fig. 19-2.

Cooling Appliance (if applicable)

The unit must have a minimum clearance of 14" from any cooling appliances such as refrigerators, kegerators, etc. See Fig. 19-3.

Heating Appliance (if applicable)

The unit must have a minimum clearance of 12" from any heating appliances such as pizza oven, griddle, etc. See Fig. 19-4.

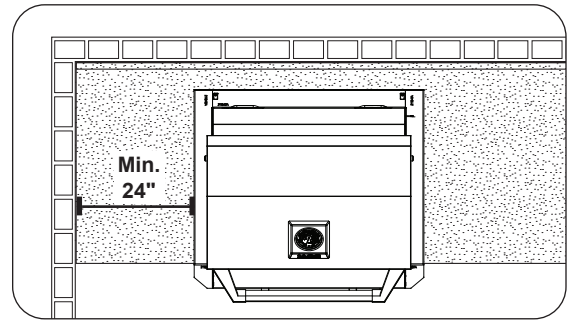

Fig. 19-1 Corner wall clearance

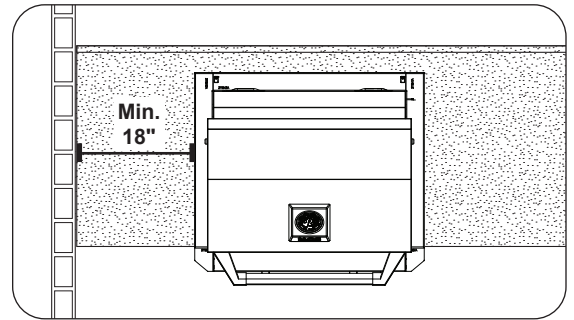

Fig. 19-2 Side wall clearance

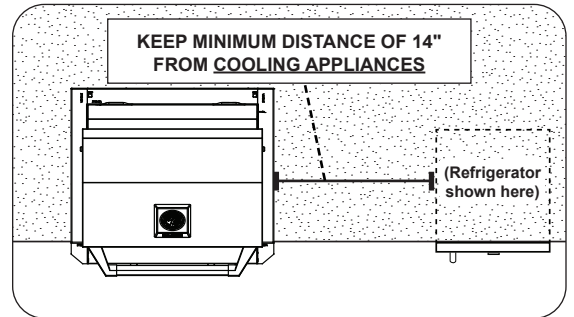

Fig. 19-3 Clearance to cooling appliances

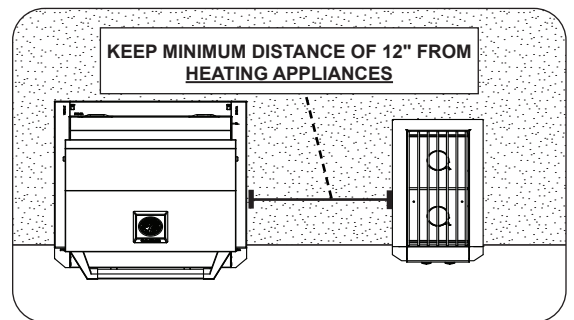

Fig. 19-4 Clearance to heating appliances

INSTALLATION REQUIREMENTS (Cont.)

FRONT PANEL CLEARANCES

The front panel **MUST** have a minimum side clearance of 6" from any obstructions/side walls to allow access to side switch. See Fig. 20-1.

The front panel **MUST** remain removable for servicing (see FRONT PANEL REMOVAL section).

COMBUSTION AIR AND COOLING AIRFLOW

Proper airflow (front-to-back, Fig. 20-2) **MUST** be maintained for the unit to perform as it was designed. If airflow is blocked, overheating and poor combustion will result. Do not block the front air inlet along the bottom of the front panel.

CAUTION: Wind blowing into or across the rear oven lid vent (Fig. 20-4) can cause poor performance and/or dangerous overheating. Install the grill so that the prevailing wind blows toward the front of the grill (Fig. 20-3). **A wind deflector is included (pre-installed) to assist in proper airflow during windy conditions. See Fig. 20-2.**

GAS-SUPPLY PLUMBING REQUIREMENTS

The gas supply is to be routed into the enclosure, near the unit. Your individual installation may vary. **Observe the National Fuel Gas Code and all local codes. Leak test at all connections.**

The gas supply must be sized to provide minimum inlet pressure at the maximum flow rate (BTU/hr). Undue pressure loss will occur if the pipe is too small, or the run is too long. Gas supply pipe must be 1/2" minimum interior diameter. If the gas line is longer than 20', a larger diameter line may be necessary. Refer to the NFPA 54 guidelines for further details.

DO NOT use a rubber hose within the enclosure.

A C.S.A. approved stainless steel flex connector (with attached regulator) is included and pre-installed to the valve manifold, and routes to the gas supply. The use of any rigid pipe, semi-rigid tubing, and connectors must comply with the Standard for *Connectors for Outdoor Gas Appliances and Manufactured Homes*, ANSI Z21. 75 (CSA 6.27).

Use a pipe joint compound resistant to all gasses on all NPT pipe fittings. Make sure to tighten every fitting securely. **Do not use pipe joint compound to connect flare fittings.**

Important: **A shut-off valve (not included) in the gas supply line is required.** It must be installed within 6 feet of the unit and must be easily accessible. Use a pipe joint compound resistant to all gasses on all NPT pipe fittings **except flare fittings.** Refer to NFPA 54 guidelines for further details.

GAS SUPPLY INLET PRESSURES:

For **natural gas** - normal 7" water column (w.c.), minimum 5", maximum 10 1/2". For **propane gas** - normal 11" w.c., minimum 10", maximum 13".

Note: An additional regulator may be needed to meet these requirements.

Note: A sediment trap in the gas supply line is recommended where applicable. It should be installed downstream of the shut-off valve as close to the unit as possible. Refer to NFPA 54 guidelines for further details.

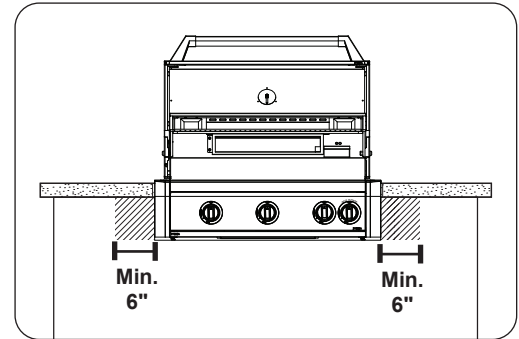

Fig. 20-1 Control panel clearances

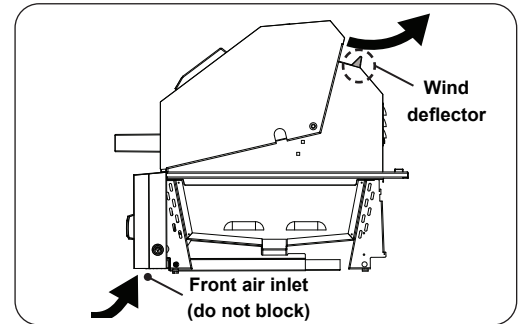

Fig. 20-2 Airflow diagram



Fig. 20-3 Airflow direction - CORRECT

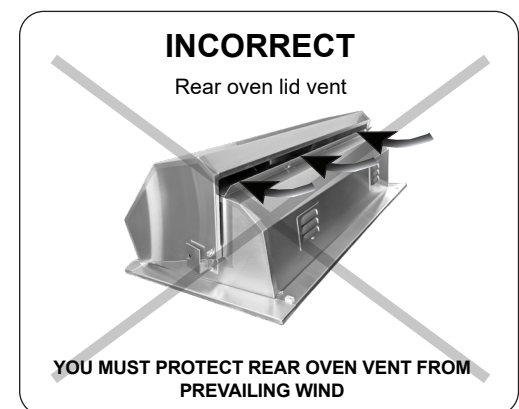

Fig. 20-4 Airflow direction - INCORRECT

DIAGRAMMATICAL REPRESENTATIONS OF OUTDOOR AREAS

The following figures are diagrammatical representations of outdoor areas, as defined in Clause 4.25.3. See INSTALLATION REQUIREMENTS section.

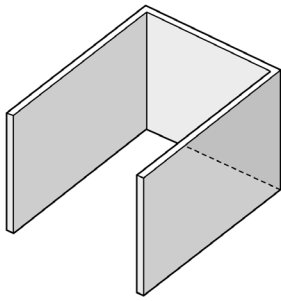

Fig. 21-1 Outdoor area - Example 1

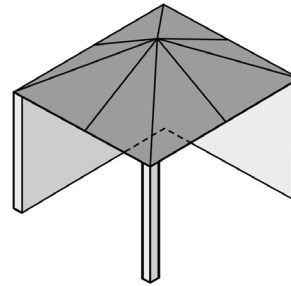
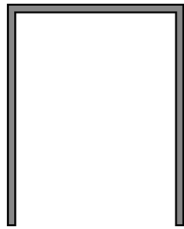

Fig. 21-2 Outdoor area - Example 2

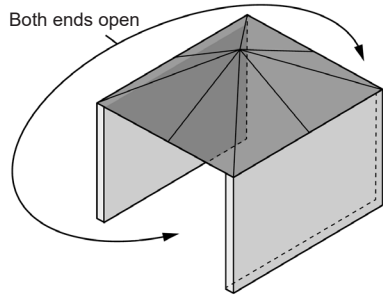
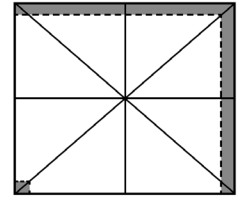

Fig. 21-3 Outdoor area - Example 3

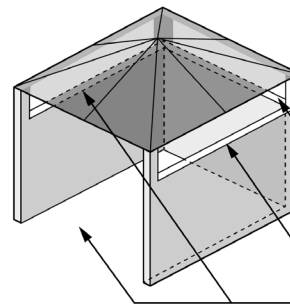
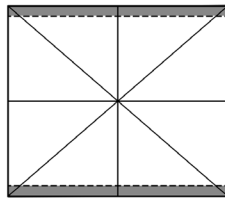
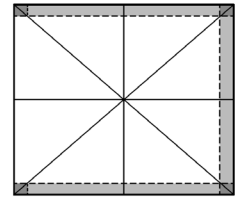

Fig. 21-4 Outdoor area - Example 4



30% or more of the horizontal periphery of the enclosure is open and unrestricted

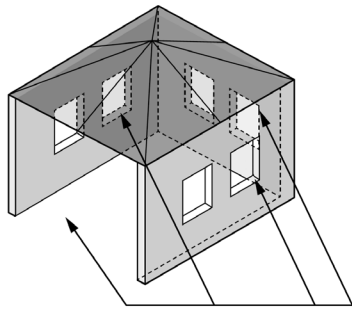
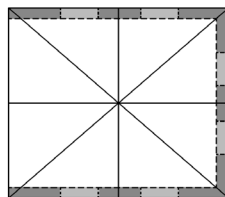

Fig. 21-5 Outdoor area - Example 5



30% or more of the horizontal periphery of the enclosure is open and unrestricted

ELECTRICAL SAFETY

- To protect against electric shock, do not immerse cord or plugs in water or other liquid.
- Unplug from the outlet when not in use and before cleaning. Allow to cool before putting on or taking off parts.
- Do not operate any outdoor cooking gas appliance with a damaged cord or plug, or after the appliance malfunctions or has been damaged in any manner. Contact the manufacturer for repair.
- Do not let the cord hang over the edge of a table or touch hot surfaces.
- Do not use an outdoor cooking gas appliance for purposes other than intended.
- When connecting, first connect plug to the outdoor cooking gas appliance then plug appliance into the outlet.
- **Use only a properly wired and inspected 120VAC (15 AMP minimum) Ground Fault Circuit Interrupter (GFCI) GROUNDED three-wire receptacle with this outdoor cooking gas appliance.**
- The GFCI receptacle must be a WEATHER-PROOF IN-USE COVERED RECEPTACLE.
- Never remove the grounding plug or use with an adapter of two prongs.
- Use only extension cords with a three-prong grounding plug, rated for the power of the equipment, and approved for outdoor use with a W-A marking.
- **The provisions of the National Electric Code as well as any local codes must be observed when installing the product.**

MODEL SPECIFICATIONS

		24"		30"		36"	
		Nat.	L.P.	Nat.	L.P.	Nat.	L.P.
Main burner	Quantity	2	2	3	3	3	3
	Orifice drill size	1.82mm	1.16mm	#50	1.16mm	#49	#56
	Air shutter opening †	1/4"	1/4"	1/4"	1/4"	1/4"	1/4"
L-Series Models	Backburner orifice drill size	#53	#64	#52	#62	#52	#62
	Input electrical requirements	120VAC / 15 AMP minimum / 60 Hz / GFCI outlet					
	Appliance rating	12VDC / 60 Watts					
	Interior oven lights rating	12V / 10 watt halogen bulb					

† These are air shutter factory settings. These settings may require adjustment due to gas conversion, altitude, or other local conditions. See AIR SHUTTER ADJUSTMENT / BURNER FLAME INSPECTION section.

Table 2 - Product Specifications

		24"	30"	36"
AOG insulating liner model # * †		24-IL-C	30-IL-C	36-IL-C
Cart base (for conversion to portable grill) model #		24CRT-25	30CRT-25	36CRT-25
Post base - patio mount (for conversion to post mount grill) model #	Standard height (37")	AOG24-PP	--	--
	Accessible height (32")	AOG24-PA	--	--
Post base - in-ground mount (for conversion to post mount grill) model #	Standard height (37")	AOG24-GP	--	--
	Accessible height (32")	AOG24-GA	--	--
Grill vinyl protective cover (For use with cart base) model # *		AOC24	AOC30	AOC36
Accent color front face panels model #	L-Series	AO-24L-***	AO-30L-***	AO-36L-***
	T-Series	AO-24T-***	AO-30T-***	AO-36T-***
	***Colors: BLK, WHT, PRD, FBE, SGY, HTL, FGN, TYW			
Double side burner accessory model #	L-Series	AOG2SBL(P)		
	T-Series	AOG2SBT(P)		
Vent hood model # *		VHD-36		
Griddle accessory model #		GR18A		
Grill complete maintenance kit model # *		MCK-1		

* If applicable, not included
† If installing this grill in a combustible enclosure, the correct AOG insulating liner must be used. Consult liner instructions for counter cutout dimensions and installation.

Table 3 - Grill Supporting Products

MODEL SPECIFICATIONS (Cont.)

Model	Height		Width	Depth
	(Top to bottom)		(Left to right)	(Front to back)
	Bottom of hanger to top		Maximum width (C)	Maximum depth (D)
	With oven lid OPEN (A)	With oven lid CLOSED (B)		
24"	22 1/4"	14"	27 7/8"	25 7/8"
30"	22 1/4"	14"	33 7/8"	25 7/8"
36"	22 1/4"	14"	40 1/8"	25 7/8"

Table 4 - Grill Dimensions

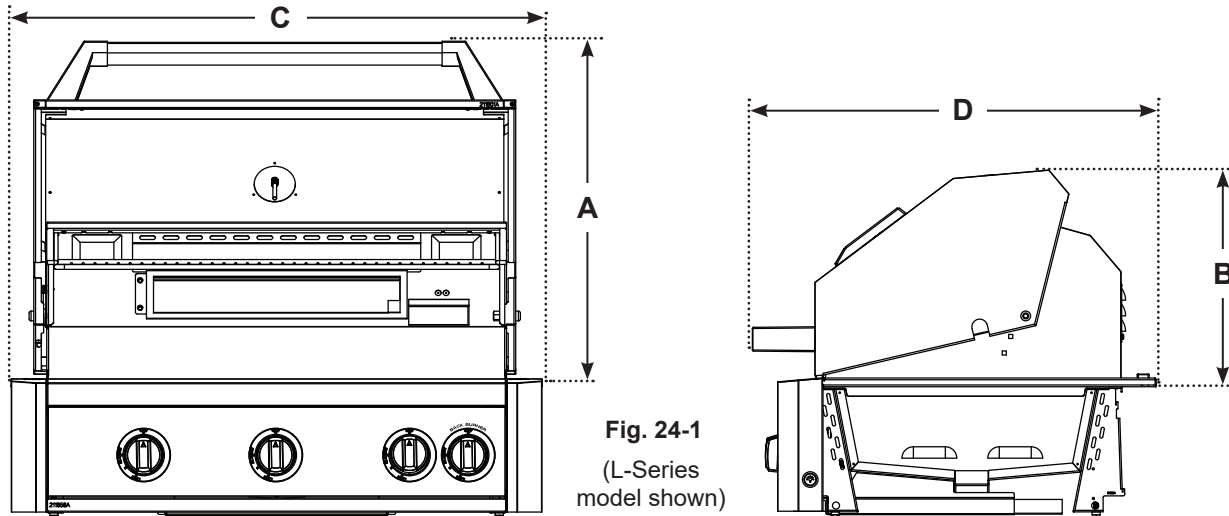

BUILT-IN L-SERIES GRILL WIRING DIAGRAM

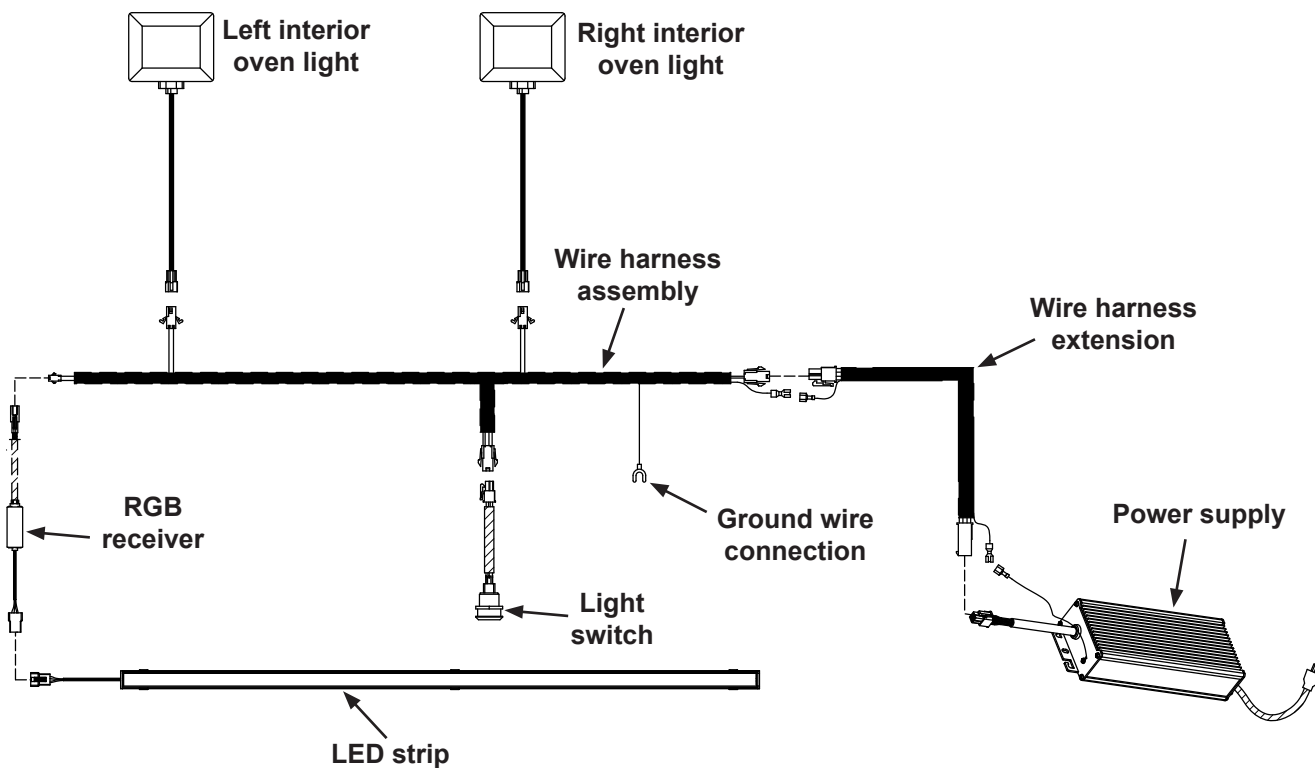

AOG GRILL REPLACEMENT PARTS LIST

IMPORTANT

This AOG oven and backburner (if equipped) are fully pre-assembled and tested at the factory.

DO NOT attempt to remove the oven and backburner from the barbecue prior to or during installation or damage to the connecting gas line and igniter wiring may occur.

Any plastic coatings, straps and tape must be removed and discarded prior to lighting the barbecue.

This note applies for all 3 size (24", 30", 36") models.

Replacement parts can be ordered from your local AOG dealer.

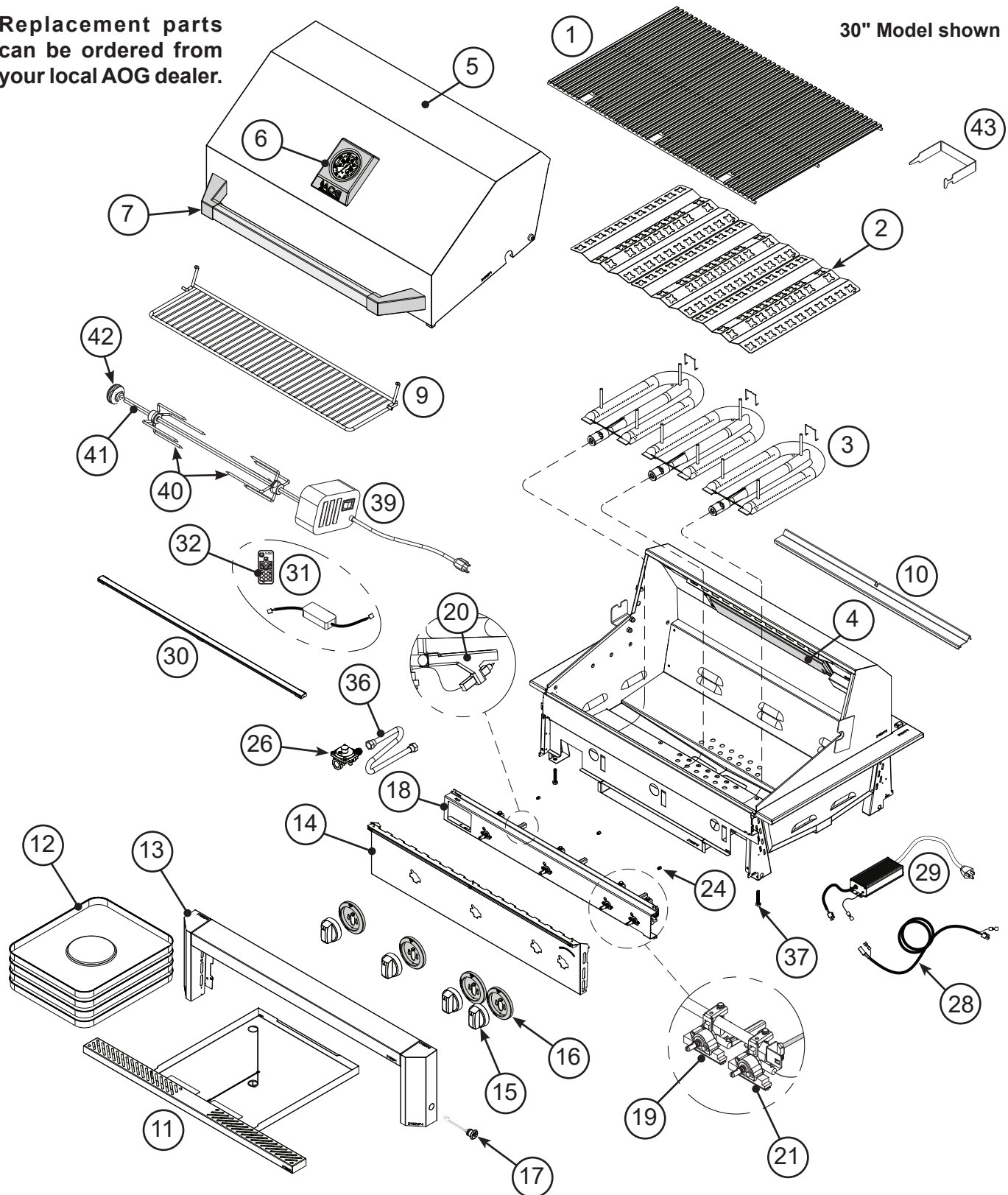

AOG GRILL REPLACEMENT PARTS LIST (Cont.)

Item	Description	L	T	24"		30"		36"	
		Series	Series	Part No.	Qty.	Part No.	Qty.	Part No.	Qty.
1.	Stainless cooking grid (set of 2 or 3)	✓	✓	24-B-11A	1	30-B-11A	1	36-B-11A	1
2.	Vaporizer panel (set of 2 or 3)	✓	✓	AO-32-24	1	AO-32-30	1	AO-32-36	1
3.	Main burner	✓	✓	24-B-06	2	24-B-06	3	24-B-06	3
4.	Backburner	✓		24-B-17A	1	30-B-17A	1	30-B-17A	1
5.	Oven lid w/ oven thermometer (no handle)	✓	✓	AO-5-24	1	AO-5-30	1	AO-5-36	1
6.	Oven lid thermometer w/ bezel (only)	✓	✓	AO-6-406	1	AO-6-406	1	AO-6-406	1
7.	Oven lid handle (only)	✓	✓	AO-7-24	1	AO-7-30	1	AO-7-36	1
8.	Oven lid spring kit	✓	✓	23729-72	1	23729-72	1	AO-8-406	1
9.	Warming rack	✓	✓	24-B-02A	1	30-B-02A	1	36-B-02A	1
10.	Wind deflector	✓	✓	AO-10-24	1	AO-10-30	1	AO-10-36	1
11.	Drip tray assembly with match holder	✓	✓	AO-11-24	1	AO-11-30	1	AO-11-36	1
12.	Drip tray liner (pack of 4)	✓	✓	3558	1	3558	1	3558	1
13.	Face frame (w/ light switch cutout)	✓		AO-12-24L	1	AO-12-30L	1	AO-12-36L	1
or	Face frame (w/o light switch cutout)		✓	AO-12-24T	1	AO-12-30T	1	AO-12-36T	1
14.	Front face panel (w/ backburner)	✓		AO-13-24L	1	AO-13-30L	1	AO-13-36L	1
or	Front face panel (w/o backburner)		✓	AO-13-24T	1	AO-13-30T	1	AO-13-36T	1
15.	Control knob (L-Series)	✓		AO-14-406	3	AO-14-406	4	AO-14-406	4
or	Control knob (T-Series)		✓	AO-14-406	2	AO-14-406	3	AO-14-406	3
16.	Control knob bezel (L-Series)	✓		AO-15-406	3	AO-15-406	4	AO-15-406	4
or	Control knob bezel (T-Series)		✓	AO-15-406	2	AO-15-406	3	AO-15-406	3
17.	Light switch	✓		24182-48	1	24182-48	1	24182-48	1
18.	Valve manifold channel assy w/ wire harness L-Series (nat. gas)	✓		AO-17-24L	1	AO-17-30L	1	AO-17-36L	1
or	Valve manifold channel assy w/ wire harness L-Series (LP gas)	✓		AO-17-24LP	1	AO-17-30LP	1	AO-17-36LP	1
or	Valve manifold channel assy T-Series (nat. gas)		✓	AO-17-24T	1	AO-17-30T	1	AO-17-36T	1
or	Valve manifold channel assy T-Series (LP gas)		✓	AO-17-24TP	1	AO-17-30TP	1	AO-17-36TP	1
19.	Main burner valve w/ igniter assy	✓	✓	24-B-51T	2	24-B-51T	3	24-B-51T	3
20.	Main burner igniter assy (only)	✓	✓	24-B-04T	2	24-B-04T	3	24-B-04T	3
21.	Backburner valve	✓		24-B-35T	1	24-B-35T	1	24-B-35T	1
22.	Backburner igniter assy †	✓		24-B-03T	1	24-B-03T	1	24-B-03T	1
23.	Backburner igniter gas tube †	✓		AO-31-406	1	AO-31-406	1	AO-31-406	1
24.	Main burner orifice, nat. gas (set of 2 or 3)	✓	✓	3001-182-2	1	3001-50-3	1	3001-49-3	1
or	Main burner orifice, L.P. gas (set of 2 or 3)	✓	✓	3001-116-2	1	3001-116-3	1	3001-56-3	1
25.	Backburner orifice, nat. gas †	✓		3001-53-1	1	3001-52-1	1	3001-52-1	1
or	Backburner orifice, L.P. gas †	✓		3001-64-1	1	3001-62-1	1	3001-62-1	1
26.	Convertible regulator	✓	✓	PR-4	1	PR-4	1	PR-4	1
27.	Wire harness assembly †	✓		AO-25-24L	1	AO-25-24L	1	AO-25-36L	1
28.	Wire harness extension	✓		24182-53	1	24182-53	1	24182-53	1
29.	Power supply	✓		24179-05	1	24179-05	1	24179-05	1
30.	LED strip assy	✓		AO-28-24L	1	AO-28-30L	1	AO-28-36L	1
31.	RGB receiver and remote control	✓		AO-29-406L	1	AO-29-406L	1	AO-29-406L	1
32.	Remote control (only)	✓		AO-30-406L	1	AO-30-406L	1	AO-30-406L	1
33.	12V / 10 watt halogen light bulb †	✓		24187-15	2	24187-15	2	24187-15	2
34.	Light lens †	✓		24187-26	2	24187-26	2	24187-26	2
35.	Lamp assembly †	✓		24187-28	2	24187-28	2	24187-28	2
36.	Flex connector w/ fittings	✓	✓	3035	1	3035	1	3035	1
37.	Support adjustment bolt (set of 2)	✓	✓	24182-47	1	24182-47	1	24182-47	1
38.	Built-in grill vinyl protective cover †	✓	✓	AOB24	1	AOB30	1	AOB36	1
39.	Stainless steel rotisserie motor	✓		24-B-32	1	24-B-32	1	24-B-32	1
40.	Spit prongs (set of 2)	✓		24-B-18	1	24-B-18	1	24-B-18	1
41.	Spit rod 5/8" hex	✓		24-B-33	1	30-B-33	1	36-B-33	1
42.	Handle knob	✓		24-B-09	1	24-B-09	1	24-B-09	1
43.	Grid lifter	✓	✓	3519	1	3519	1	3519	1

† Not shown

INSTALLATION

It is not required to remove the front panel or knobs to install this unit.

DO NOT lift the unit from the front panel when installing.

BUILD / CONSTRUCT ENCLOSURE

GFRC islands are available (for select models). They accommodate your grill and side cooker/accessories. Build the enclosure per the instructions supplied with the unit.

Alternatively, a custom-built enclosure can be constructed. Construct the enclosure according to your individual install preference, while following the guidelines found in the ENCLOSURE REQUIREMENTS and INSTALLATION REQUIREMENTS sections.

- Construct the enclosure in an appropriate location (ensure all requirements of this manual and all local codes are met when determining location).
- **Follow all information regarding enclosure parameters, ventilation, drainage, cylinder requirements, cutout dimensions, and clearances listed in the ENCLOSURE REQUIREMENTS and INSTALLATION REQUIREMENTS sections.** Failure to do so will prevent proper operation and can cause property damage or personal injury.

INSTALL INSULATING LINER (if applicable)

If installing your unit in a combustible enclosure, the correct insulating liner must be used. Refer to the instructions supplied with the liner for installation.

SLIDE UNIT INTO ENCLOSURE CUTOUT

CAUTION: THE GRILL IS HEAVY AND REQUIRES TWO OR MORE PEOPLE FOR SAFE HANDLING.

1. Prepare the grill for installation.

- Remove any packaged items from inside the grill oven.
- L-Series grills: Locate the power supply, disconnect the harness extension from the power supply, and set the power supply aside. See Fig. 27-2.

2. Carefully slide the unit into the enclosure cutout, being sure to simultaneously route the flex connector (with attached regulator) and harness extension (if equipped) down into the enclosure. (If using an insulating liner or if the enclosure has a solid area beneath the unit, route the connections through the designated holes/cutouts. The regulator must be disconnected from the flex connector for it to feed through the cutout. For hole/cutout details, see the Cutout Dimensions section in ENCLOSURE REQUIREMENTS or refer to the instructions supplied with the liner.)

- Ensure the gas connections (and electrical, if equipped) are clear, undamaged, and completely inserted into the cutout, and that the unit is correctly inserted without any obstructions between it and the countertop.
- Ensure the unit fully slides in so that the front panel sits flush against the enclosure front wall. See Fig. 27-3 and the Counter Overhang section in ENCLOSURE REQUIREMENTS for details.
- If installing on a countertop with an irregular/textured surface, a bead of silicone sealer rated for 400° F (204° C) or higher between the countertop and hanger is recommended to protect from the elements.

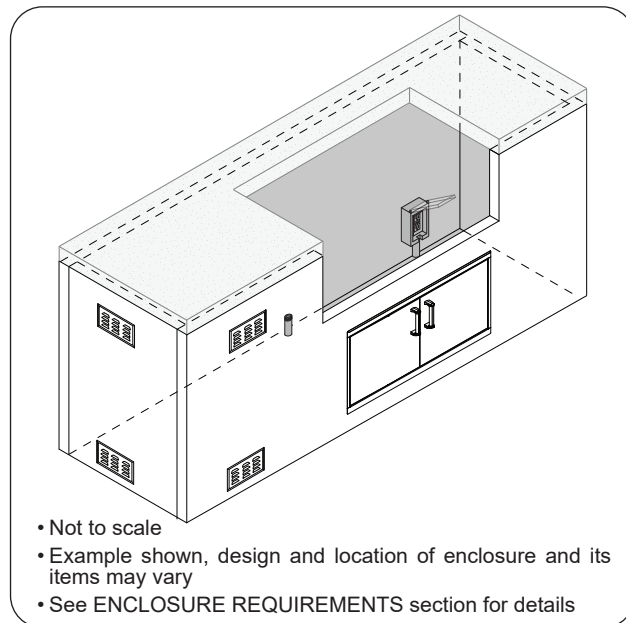

- Not to scale
- Example shown, design and location of enclosure and its items may vary
- See ENCLOSURE REQUIREMENTS section for details

Fig. 27-1 Enclosure construction overview (as applicable)

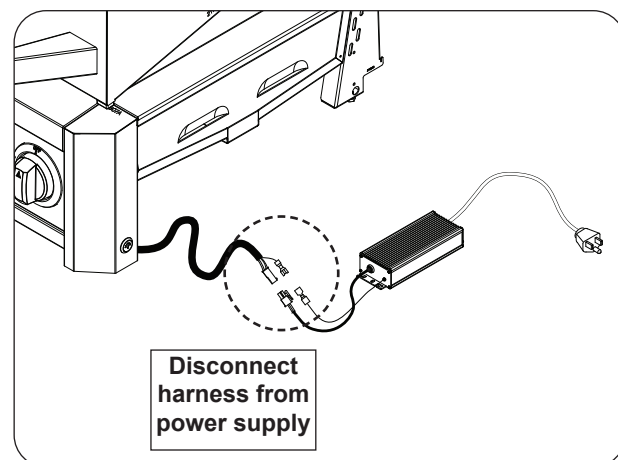

Fig. 27-2 Disconnect harness

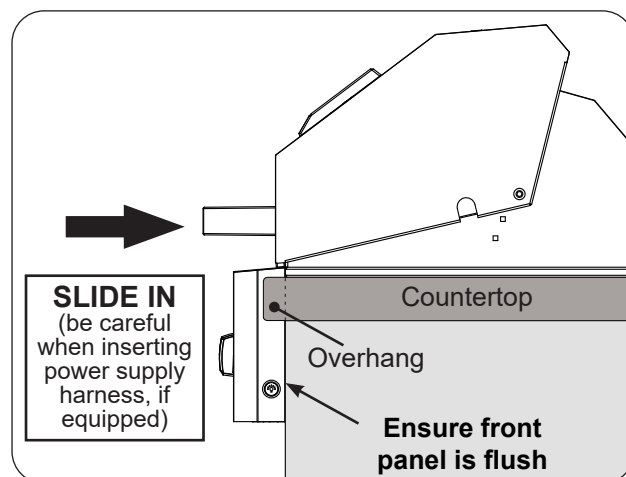

Fig. 27-3 Slide in unit (ensure flush)

3. Rotate the front support adjustment bolts (up or down) until the grill hanger rests flush on the countertop, AND, the adjustment bolts are touching the supporting structure found at the bottom of the cutout (lower support). Use a 7/16" open-end wrench as needed. See Fig. 28-1.
 - The grill should not solely rest on just the hanger or just the adjustment bolts.
 - The bolts **MUST** be used to provide support to the hangers.
4. Reconnect the harness extension to the power supply (See Fig. 28-2).

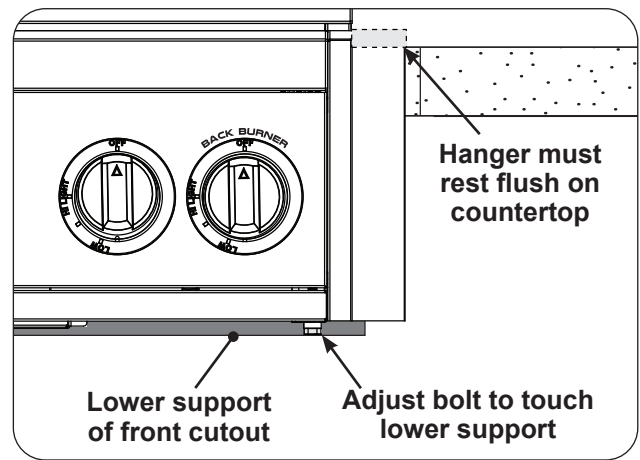

Fig. 28-1 Front support adjustment bolts

CONNECT GAS SUPPLY

Important: The regulator **MUST** be installed upstream between the gas supply and the unit.

To Connect To Propane Cylinder:

Read the safety warnings and follow the instructions in the section **SAFE USE AND MAINTENANCE OF PROPANE GAS CYLINDERS**.

Note: When a propane cylinder is installed inside of the enclosure, the guidelines found in the **ENCLOSURE REQUIREMENTS** section **MUST** be followed.

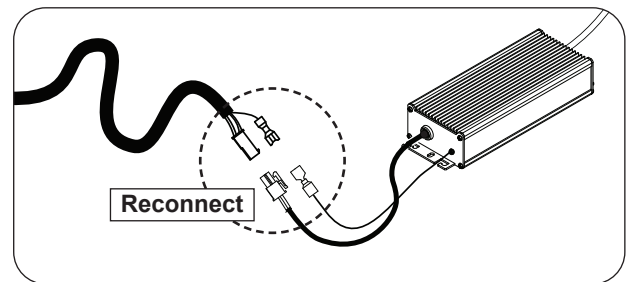

Fig. 28-2 Reconnect harness

To Connect To Natural Or Household Propane Gas Supply:

CAUTION: Use only C.S.A. listed stainless-steel flex connectors within the enclosure.

WARNING

A rubber or plastic connector will rupture or leak, resulting in an explosion or serious injury if used inside the appliance enclosure.

- Before connecting the gas supply to your appliance, pressures **MUST** be tested and **MUST NOT** exceed 10.5" w.c. for Nat. gas and 13" w.c. for L.P. gas. An additional regulator may be required.
- Refer to the **GAS SUPPLY PLUMBING REQUIREMENTS** section for all details on the gas supply and its setup.

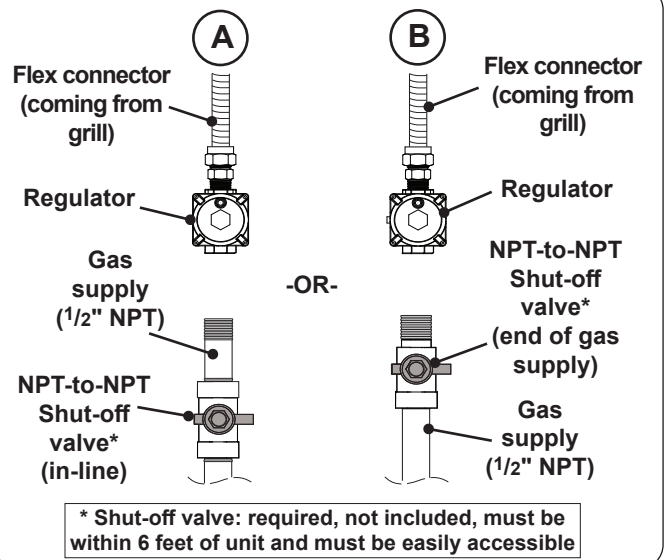

Fig. 28-3 Household propane & natural gas diagram

1. **Turn OFF the gas supply at the source.**
2. Run the attached flex connector with regulator (coming from the left side of the grill) to the gas supply stub.
3. A shut-off valve is required within 6 feet of the unit and must be easily accessible.
 - Connect the regulator (on end of flex connector) to the gas supply (1/2" NPT) OR shut-off valve (1/2" NPT) using a pipe joint compound resistant to all gases (see Fig. 28-3, A or B). Tighten securely. The regulator may need to be disconnected from the flex connector to make the proper connections. Reconnect the flex to the regulator if removed.

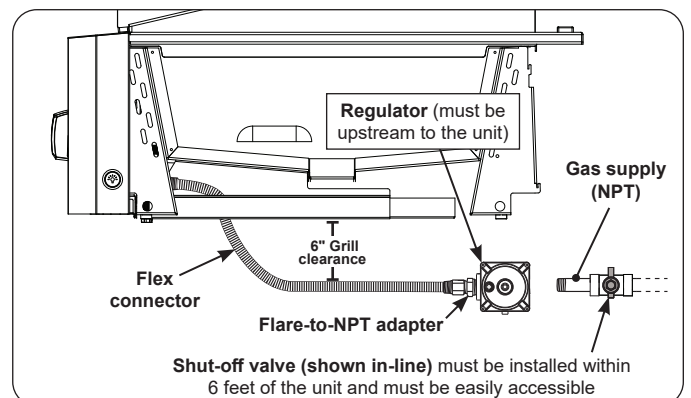

Fig. 28-4 Connecting to a gas line

LEAK TEST

Turn all burner valves to the **OFF** position. Turn on the gas supply, and test at all connections for leaks using a soapy water solution. If bubbles appear, a leak is present. Turn off the gas and tighten at all connections. Repeat until no leaks are present. If a leak persists, turn off the gas supply and contact the local gas company or dealer. **NEVER USE A FLAME TO CHECK FOR LEAKS.**

Once the leak test is complete, turn off the gas supply and proceed.

INSTALL VAPORIZER PANELS

Place the vaporizer panels directly onto the studs on the burners. See Fig. 29-1. The panels allow heat from the burners to be evenly distributed throughout the cooking area. The panels are stainless steel and will heat and cool quickly, making your grill very responsive to the changes you specify in grill temperature. They are rust resistant and may be cleaned with standard oven cleaners. Some discoloring will be seen with use. This is normal for stainless steel and does not affect the function.

INSTALL COOKING GRIDS

Note: Wear heat-resistant gloves if necessary.

Note: Do not leave the lifter on any hot surfaces.

1. With the prongs facing downward, insert the notched-end of the lifter between two grid rods, then rotate, as shown in Fig. 29-2, A & B.

Note: To balance, insert the notched-end of the lifter in the middle front half of the cooking grid.

2. Insert the rear pointed-end of the lifter between the same two rods (Fig. 29-2, B) and carefully lift the cooking grid and place onto the front and rear grid rests of the grill (see Fig. 29-3). Repeat for all other cooking grids.

INSTALL DRIP TRAY

Your grill includes a pack of four drip tray liners. Place a liner into the drip tray. The liner must fit under the two front tabs of the drip tray. Insert the drip tray into the slot found below the front panel and slide it in completely. See Fig. 29-4.

INSTALL WARMING RACK

The warming rack (Fig. 29-5) is packed separately. To install the warming rack, carefully insert the rack hangers into the two holes in the back of the inner oven hood, then lower the front of the rack to a level position.

Note: Removing the warming rack before using the rotisserie will leave more clearance for the meat being cooked (if applicable).

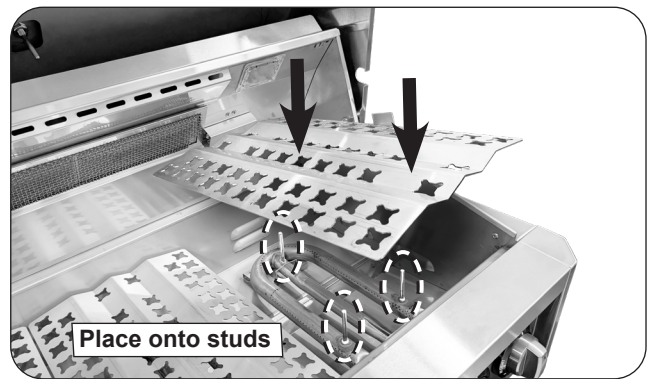

Fig. 29-1 Install vaporizer panels

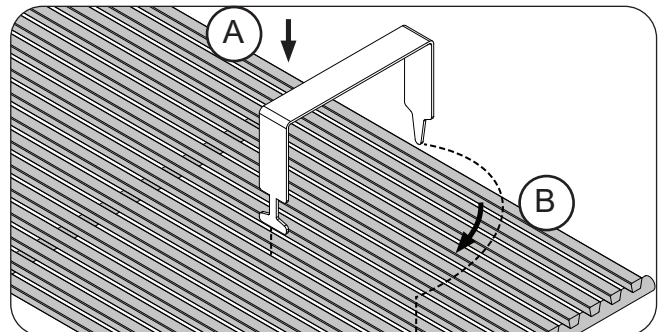

Fig. 29-2 Install cooking grids

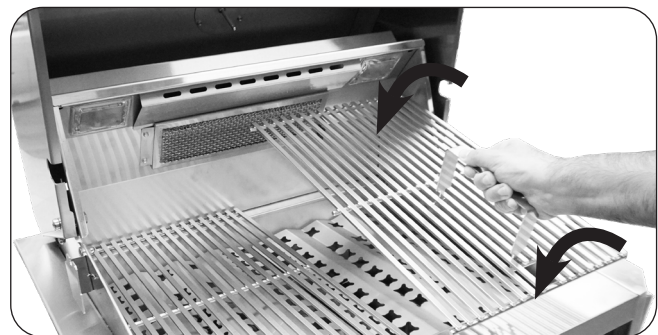

Fig. 29-3 Install cooking grids

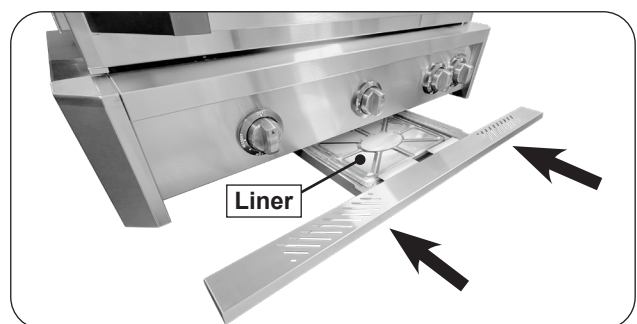

Fig. 29-4 Install drip tray



Fig. 29-5 Install warming rack

INSTALL POWER SUPPLY (if equipped)

If a double side burner is being installed and will be powered using the same grill power supply, instead refer to the **POWER SUPPLY / WIRE HARNESS CONNECTIONS section of the owner's manual included with the side burner for power supply installation.**

The electrical connections from the power supply box to the grill should already be connected at this point.

CAUTION: IMPROPERLY CONNECTED WIRES WILL CAUSE DAMAGE TO THE UNIT AND MAY RESULT IN PROPERTY DAMAGE AND/OR PERSONAL INJURY.

1. Route the harness extension in the enclosure directly downward. This will prevent overheating. **DO NOT** route the harness below the unit firebox. See Fig. 30-2.
2. Mount the power supply to the inside of the enclosure using appropriate hardware for your enclosure. **The power supply MUST BE:**
 - located at least **12"** below the bottom of the unit (see Fig. 30-1)
 - protected from weather/elements
3. Connect the power cord to a **120VAC (15 AMP minimum) GFCI GROUNDED three-wire receptacle** (see Fig. 30-1). The GFCI receptacle must be a WEATHER-PROOF IN-USE COVERED RECEPTACLE.

WARNING: Electrical Grounding Instructions - This appliance is equipped with a three-pronged (grounding) plug for your protection against shock hazard and should be plugged directly into a properly grounded three-prong receptacle. Do not cut or remove the grounding prong from this plug.

1. Locate power supply
2. Route wire harness extension downward
3. Mount power supply
4. Connect cord to power source

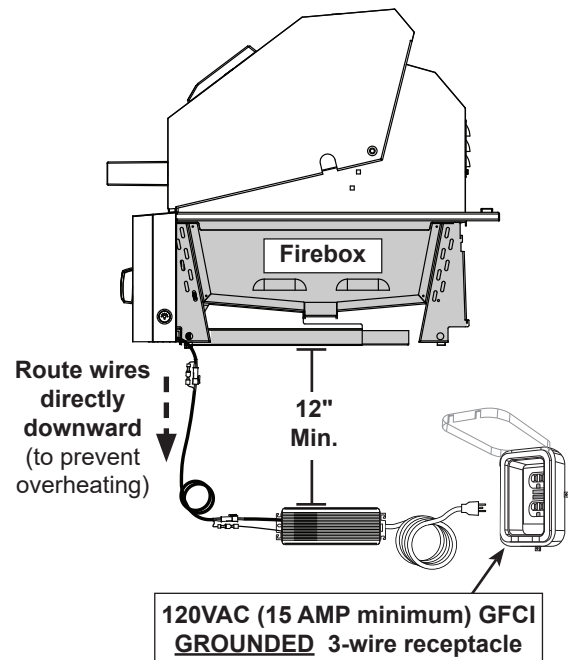

Fig. 30-1 Electrical installation

OPERATION TEST

After installation, perform an operation test of the grill and its features/accessories. Refer to the following sections for details.

IDENTIFICATION OF GRILL CONTROLS

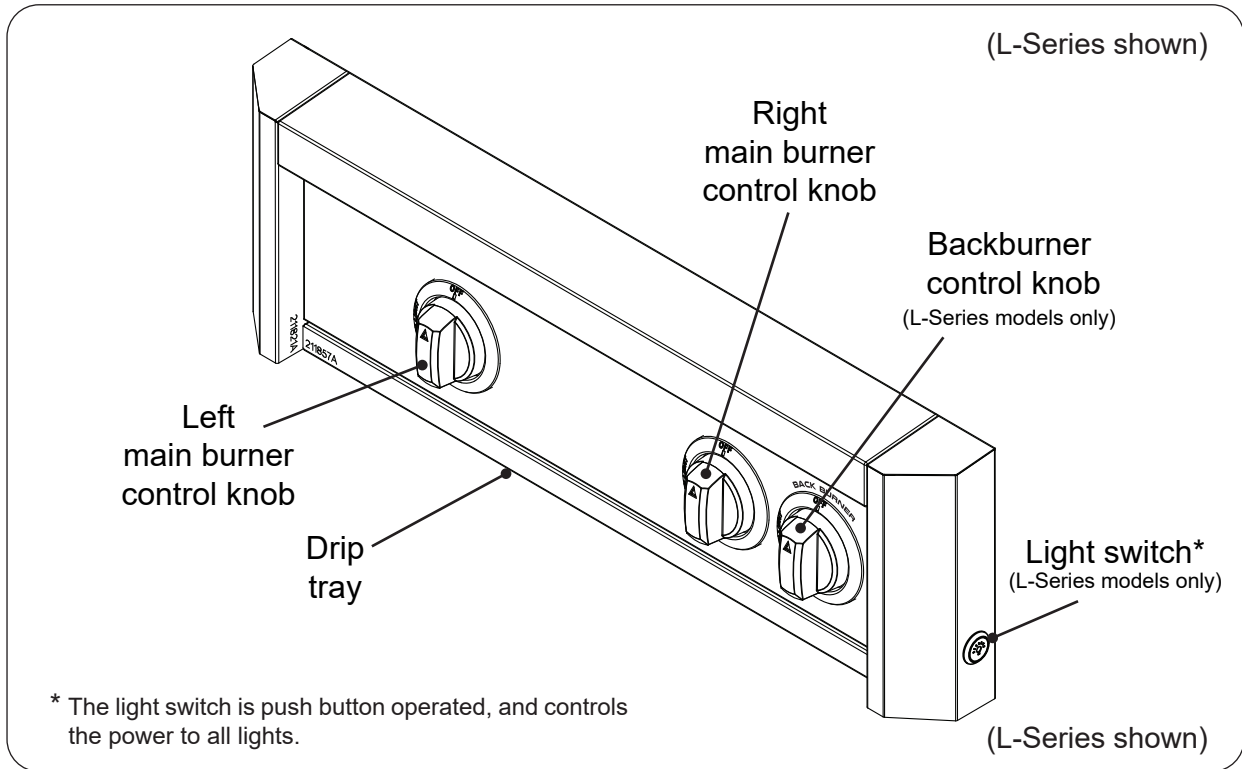

Fig. 31-1 24" model controls

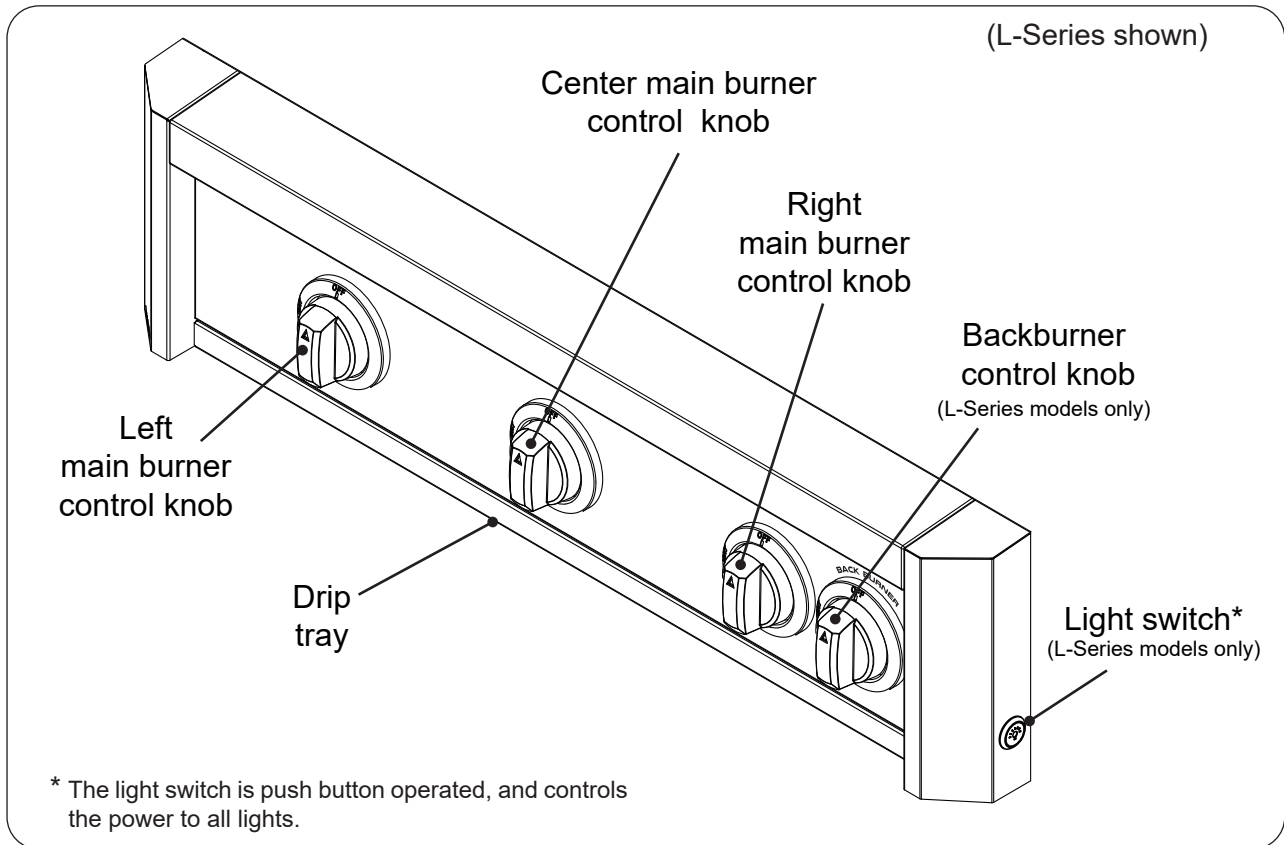

Fig. 31-2 30" and 36" model controls

USING THE APPLIANCE

BEFORE INITIAL USE

Ensure that:

- the unit has been properly installed and leak tested by a qualified professional service technician and as instructed in this manual.
- you have read and understand all of the information in this manual.

BEFORE EACH USE

Ensure that:

- you smell around the appliance area for gas. If you smell gas (and all control knobs are in the **OFF** position), immediately shut off the gas supply and contact a qualified professional service technician or the gas supplier for inspection.
- the required vent openings and surrounding area of the enclosure are clear at all times.
- the cooking area and drip tray are clean, and the drip tray is properly installed.
- you inspect all piping and hoses for damage, cuts, wear, and tear. Replace any damaged components prior to use.

OPERATION

- The unit becomes **HOT** during use. **NEVER** touch any part of the cooking area or surrounding hot surfaces with bare hands. Use long-handled insulated BBQ tools and wear an insulated glove / oven mitt.
- Always keep your face and body as far from the unit as possible during use. Avoid wearing loose-fitting clothing as they could ignite.
- This appliance is designed as an attended appliance. **DO NOT** leave this appliance burning when unattended.
- **NEVER** cover more than 75% of the cooking surface with griddles, pots or pans to prevent overheating.
- After each use, turn the control knob(s) to the **OFF** position and turn off the gas supply to the unit.

After reading and understanding all bullets above, follow these steps to light and use your grill:

1. Light the grill per the LIGHTING INSTRUCTIONS section.
2. Turn the control knobs to the HI-LIGHT position, close the hood, and allow the grill to preheat for 15 minutes or until desired cooking temperature is reached.
3. Place the food on the grill and cook as desired. Monitor the flames and the temperature, and adjust the heat setting if necessary.
4. See the sections below and the following pages for all other information regarding use.

WIND CONSIDERATIONS

Proper airflow (front-to-back, Fig. 32-1) MUST be maintained for the unit to perform as it was designed. See the INSTALLATION REQUIREMENTS section for details.

When using the unit in windy conditions, the wind can disrupt the airflow and cause overheating. To prevent overheating during windy conditions, do not leave the hood closed with the burners on high for more than 15 minutes.

AFTER EACH USE

1. Operate on high with hood closed for 10-15 minutes to burn off all grease.
 2. Turn off the grill and brush/scrape the cooking grids to remove all residue.
- CAUTION:** Use long-handled insulated BBQ tools and wear an insulated glove / oven mitt.
3. When the grill is cool, check and clean the drip tray. Then cover the grill (see section below).
 4. For additional cleaning information, refer to the SERVICING AND CLEANING section.

COVER THE GRILL

Place the cover over your unit, with the AOG logo facing forward. Pull the front portion of the cover (lined with elastic) under the front face of the unit. Then, hook the left and right straps under the notches of the grill rear hanger. See Fig. 32-2.

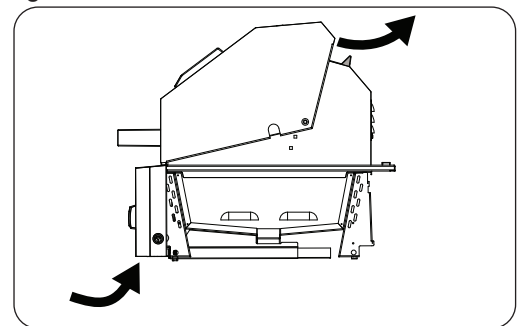

Fig. 32-1 Airflow diagram

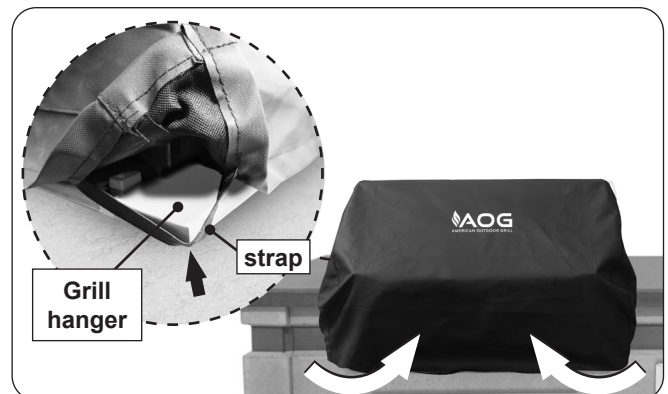

Fig. 32-2 Cover grill

LIGHTING (IGNITION) INSTRUCTIONS

Read all instructions before lighting, and follow these instructions each time you light the unit.

SPARK IGNITION LIGHTING

1. Remove the protective vinyl cover and open the oven lid.
2. Turn all gas control knob(s) to their **OFF** position(s).
3. Turn on the gas at its source. If applicable, set the timer control knob to the desired cooking time. See **SETTING THE TIMER** section below.

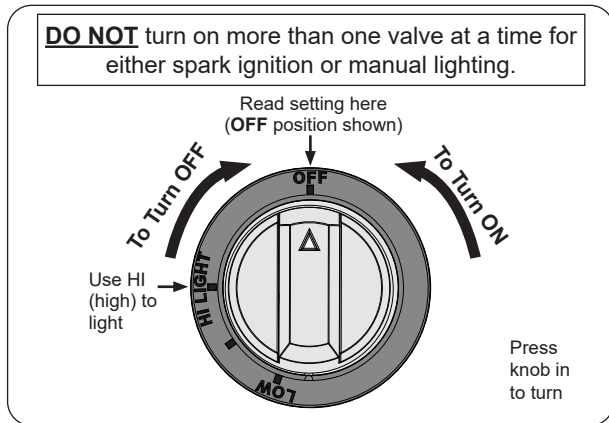

Fig. 33-1 Control knob

4. Depress the desired control knob, and while pressing turn it counterclockwise to the **HI LIGHT** position (Fig. 33-1). Once the burner lights, release the knob.

Note: Turning the knob will create a “click” sound and ignite the burner. If there is no ignition, immediately turn to **OFF** position and repeat sequence quickly until burner ignites.

CAUTION: If a burner does not light within five (5) *seconds* of turning on the control knob, depress the knob and turn it to the **OFF** position. **WAIT FIVE (5) MINUTES** before repeating step 5. If you smell gas, follow the instructions on the cover of this manual. If the burners still do not light after several attempts, refer to the instructions for manual lighting.

5. Repeat step 5 for each additional burner to be lit.

SETTING THE TIMER (IF APPLICABLE NOT INCLUDED)

If your grill is installed in a post base (sold separately) the timer (equipped with the post base) must **first** be set. To use, set the dial (turn clockwise) to the desired time to shut off, up to 1 hour. The timer dial will automatically rotate (counter-clockwise) to **OFF** (gas supply will shut off).

Important: When using the timer for periods of less than twenty minutes (to activate), then return (counter-clockwise) to the desired amount of time. This will ensure proper timer operation. See Fig. 33-3.

Note: Harsh environments, wear, abuse, or tampering may affect your timer. It is recommended to periodically test the timer at least once a month or as needed.

- Ensure when timer reaches the **OFF** position, no gas continues to flow.
- If the timer does not shut off, have a gas professional replace the timer.

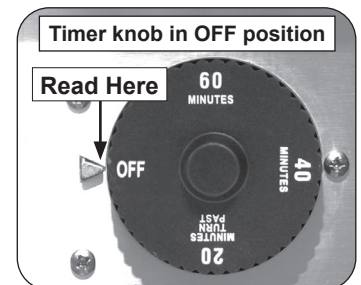

Fig. 33-3 Timer dial

MANUAL LIGHTING

CAUTION: Always wait five (5) *minutes* for gas to clear after any unsuccessful lighting attempt.

1. Follow steps 1 through 3 (left).
2. Insert either a burning long-barrel butane lighter, a burning long-stem match, or a burning match held by a wire extension holder through the cooking grids to the burner (Fig. 33-2). For backburners, hold the flame against the perforated material of the backburner.
3. While holding the match or lighter flame next to the burner, depress the appropriate control knob and while pressing turn it counterclockwise to the **HI LIGHT** position. Remove the lighter or match when the burner lights, and release the control knob.

CAUTION: If the burner does not light within five (5) *seconds* of turning the control knob, **immediately depress the knob and turn the valve to OFF. WAIT FIVE (5) MINUTES** before repeating steps 2 and 3 of the **MANUAL LIGHTING** instructions.

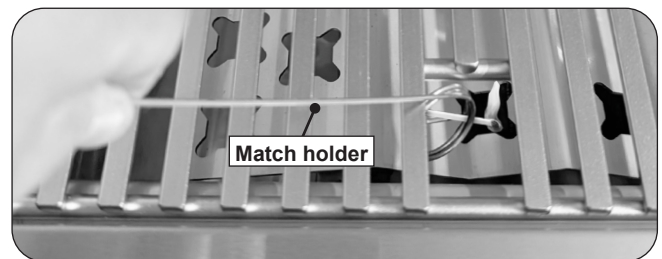

Fig. 33-2 - Manual lighting

SHUTTING OFF THE UNIT

To shut off the unit, depress each valve control knob and while pressing turn it clockwise to the **OFF** position. After each use, always close the valve from the gas supply of the unit.

Ensure the light switch is in the **OFF** position.

WHEN USING A PORTABLE PROPANE TANK

Propane tanks are equipped with a safety shutdown device that may cause low or no gas pressure/flame at the burners if operating and lighting instructions are not followed exactly (See important note in the **TROUBLESHOOTING** section for more details).

ALLUMAGE DES INSTRUCTIONS (D'ALLUMAGE)

Lisez toutes les instructions avant l'allumage, et suivez ces instructions chaque fois vous lumière le unité.

ALLUMAGE COMMANDE ÉCLAIRAGE

1. Retirez le film de protection et ouvrez le couvercle du four.
2. Tournez tous les boutons de commande du gaz sur leur position **OFF**.
3. Allumez le gaz à sa source. Le cas échéant, placez le bouton de commande du temporisateur sur le temps de cuisson souhaité. Voir la section RÉGLAGE DE LA MINUTERIE.

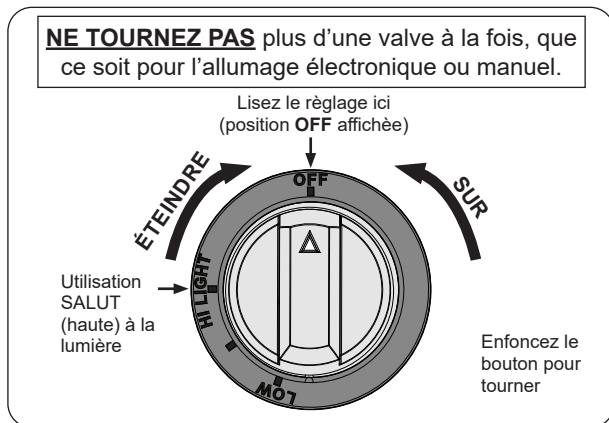

Fig. 34-1 Bouton de commande

4. Appuyez sur le bouton de commande souhaité et, tout en appuyant sur cette touche, tournez-le dans le sens inverse des aiguilles d'une montre jusqu'à la position **HI LIGHT** (Fig. 34-1). Une fois le brûleur allumé, relâchez le bouton.

Remarque: Tourner le bouton crée un « clic » et allume le brûleur. S'il n'y a pas d'allumage, mettez-le immédiatement sur **OFF** et répétez la séquence rapidement jusqu'à ce que le brûleur s'allume.

ATTENTION: Si un brûleur ne s'allume pas dans cinq (5) secondes d'allumer le bouton de commande, enfoncez le bouton et tournez-le à la position **OFF**. ATTENDEZ CINQ (5) MINUTES avant de répéter l'étape 4. Si vous sentez le gaz, suivez les instructions sur la couverture de ce manuel. Si les brûleurs ne s'allument toujours pas après que plusieurs tentatives, se rapportent aux instructions pour l'éclairage manuel.

5. Répétez l'étape 4 pour que chaque brûleur additionnel soit Lit.

RÉGLAGE DE LA MINUTERIE (SI APPLICABLE NON INCLUS)

Si votre barbecue est installé sur une base de poteau (vendue séparément), réglez d'abord la minuterie (intégrée à la base). Tournez le cadran (sens horaire) jusqu'au temps d'arrêt désiré, maximum 1 heure. Le cadran revient ensuite automatiquement (sens antihoraire) à **OFF** et coupe l'alimentation en gaz.

Important: Pour utiliser la minuterie pour des durées inférieures à vingt minutes, tournez au-delà de vingt (pour l'activer), puis revenez (dans le sens antihoraire) à la durée souhaitée. Cela garantit le bon fonctionnement de la minuterie. Voir Fig. 34-3.

Remarque: Les conditions difficiles, l'usure ou une mauvaise manipulation peuvent affecter la minuterie. Il est recommandé de tester périodiquement la minuterie au moins une fois par mois ou selon les besoins.

- Assurez-vous qu'aucun gaz ne s'écoule lorsque la minuterie atteint la position **OFF**.
- Si la minuterie ne s'éteint pas, faites-la remplacer par un professionnel du gaz.

EMPLOYANT UN RÉSERVOIR DE PROPANE PORTATIF

Des réservoirs de propane sont équipés d'un dispositif d'arrêt de sûreté qui peut ne pas causer le bas ou aucunes pression de gaz/flamme aux brûleurs si le fonctionnement et l'allumage des instructions ne sont pas suivis exactement (voir la note importante dans la section de DÉPANNAGE pour plus de détails).

ÉCLAIRAGE MANUEL

ATTENTION: Attendez toujours cinq (5) minutes le gaz pour se dégager après que n'importe quelle tentative non réussie d'éclairage.

1. Suivez les étapes 1 à 3 (à gauche).
2. Insérez soit un brûlant long baril briquet au butane, un match à longue tige de brûlure, ou une allumette en feu détenues par un titulaire d'extension de fil À travers les grilles de cuisson du brûleur (Fig. 34-2). Pour backburners, maintenez la flamme contre le matériau perforé de la veilleuse.
3. Tout en maintenant le match ou flamme d'un briquet à proximité du brûleur, appuyez sur le bouton de contrôle approprié et en appuyant son tour dans le sens antihoraire à la position **HI LIGHT**. Retirez le briquet ou des allumettes quand le brûleur s'allume, puis relâchez le bouton de commande.

ATTENTION: Si le brûleur ne se allume pas dans les cinq (5) secondes de tourner le bouton de commande, appuyez immédiatement sur le bouton et tournez la valve sur **OFF**. ATTENDEZ CINQ (5) MINUTES avant de répéter les étapes 2 à 3 des instructions du MANUEL D'ÉCLAIRAGE.

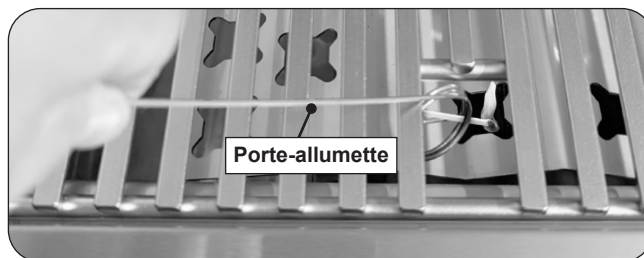

Fig. 34-2 - Allumage manuel

ARRÊT DU UNITÉ

Pour éteindre l'appareil, appuyez sur chaque bouton de commande de valve et, tout en maintenant la pression, tournez-le dans le sens horaire jusqu'à la position **OFF**.

Après chaque utilisation, fermez toujours la vanne de l'alimentation en gaz de l'appareil. Assurez-vous que l'interrupteur d'éclairage est en position **OFF**.

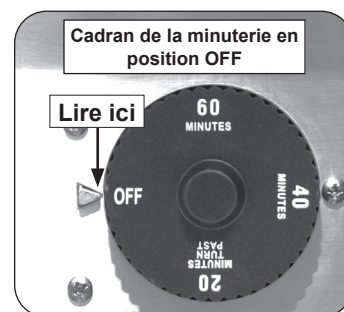

Fig. 34-3 Cadran de la minuterie

ROTISSERIE INSTRUCTIONS (if equipped)

CAUTION: WHEN USING THE BACKBURNER; KEEP THE OVEN LID CLOSED TO PREVENT HEAT LOSS, PROVIDE PROPER CONVECTION, AND PROVIDE PROPER VENTING. THIS WILL ENSURE EVEN COOKING TEMPERATURES.

DO NOT KEEP YOUR OVEN LID OPEN DURING ROTISSING, AS THIS MAY CAUSE PERSONAL INJURY, OR IN SOME CASES, IN WINDY CONDITIONS, DAMAGE TO THE GRILL.

DO NOT USE THE ROTISSERIE MOTOR IN THE RAIN. DO NOT LEAVE THE MOTOR ON THE GRILL WHEN NOT IN USE.

1. Remove the warming rack and cooking grids from the barbecue. The vaporizer panels may also be removed if required.

Tip: Aluminum foil or a baking pan is recommended and may be placed over the main burners / vaporizer panels, a little forward of center, to catch excess drippings from the meat.

2. Attach the rotisserie motor to the rotisserie mounting on the right side of your barbecue by sliding the bracket attached to the motor onto the tab on the right of the barbecue. The motor should be installed so that the spit rod will fit into the motor drive socket from the left.

3. Slide the left spit prong onto the rod (and tighten), the meat onto the rod and into the prong, followed by the right spit prong onto the rod and into the meat. Tighten the right spit prong. Be sure the meat is centered and balanced as well as possible.
4. Insert the pointed end of the rod into the motor drive socket and the groove next to the handle into the left support bracket.
5. Plug in (if necessary) and turn on the rotisserie motor.
6. Light backburner per lighting instructions in this manual (or on drip tray handle) and close oven lid.
7. Allow the backburner to preheat for approximately 10 minutes on **HI LIGHT** setting.

Note: When burning properly, the backburner grating will glow red. The first time it is used the backburner may smoke a little.

Important: Turn the backburner to low or off when stopping the rotisserie to prevent overcooking.

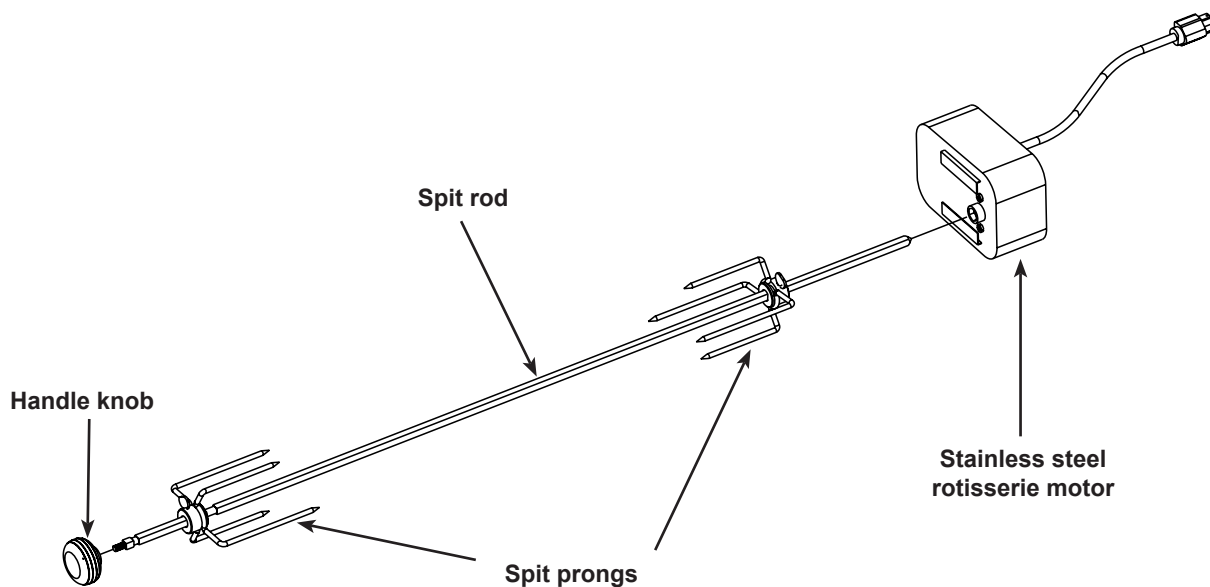

LED LIGHT REMOTE OPERATION

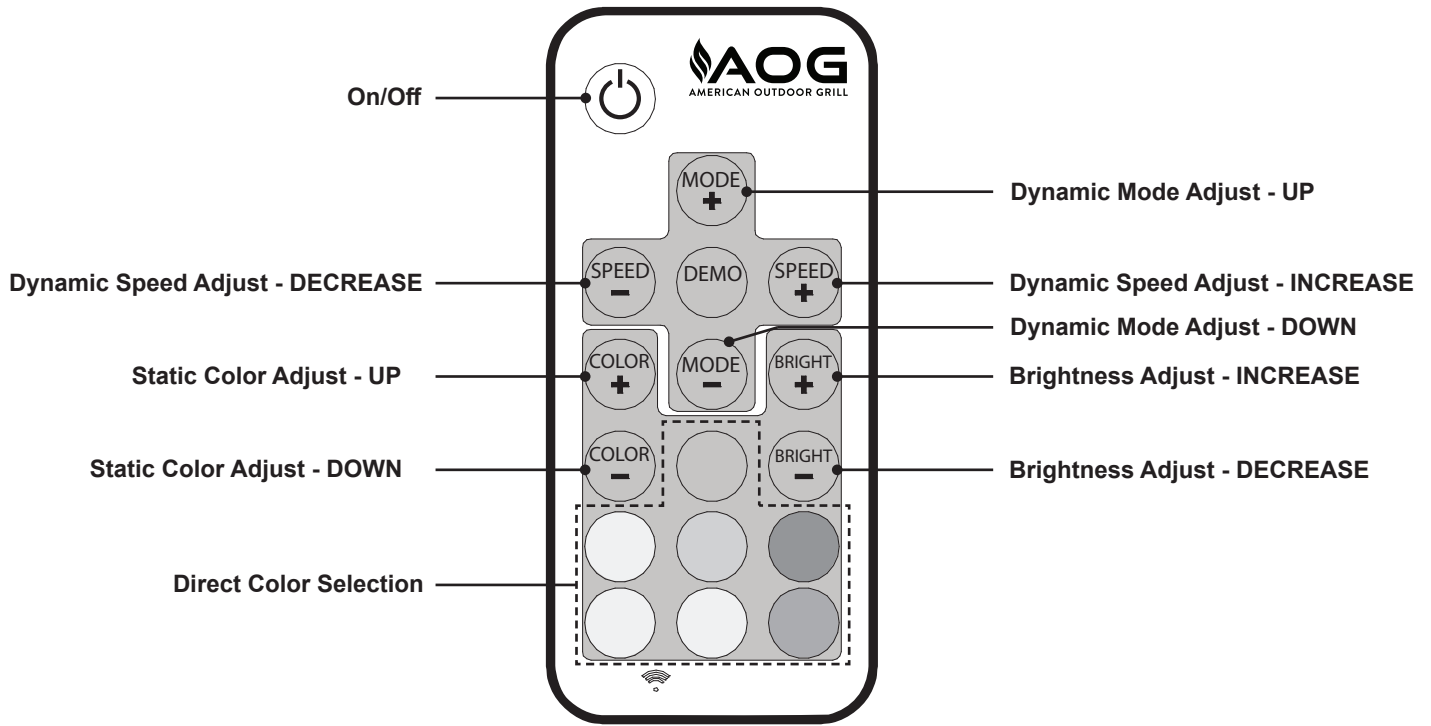

Fig. 36-1 Remote details

REMOTE OPERATION

BEFORE FIRST USE: Activate the battery by removing the insulating strip to enable battery contact.

WHEN USING: The RF wireless remote signal passes through barriers. It does not require aiming the remote at the unit to operate.

On/Off Key

Press this key to turn the lights on or off. At power on, the unit will automatically turn on and restore to its previous status.

Dynamic Mode Adjust Keys

Press the dynamic mode adjust keys (+ or -) to switch to dynamic mode or to switch between patterns in this mode.

Dynamic Speed Adjust Keys

Press the dynamic speed adjust key (+ or -) to increase or decrease the speed of the dynamic mode pattern that is in operation.

Note: The light setting will switch to dynamic mode if these keys are pressed while in static color mode.

Static Color Adjust Keys

Press the static color adjust keys (+ or -) to switch to static color mode or to switch between static colors.

Note: The range of colors corresponds to the predefined colors on the remote.

Direct Color Select Keys

Press the desired color select key to choose a predefined color.

Brightness Adjust Keys

Press the brightness adjust keys (+ or -) to increase or decrease the brightness of the lights.

Note: The light setting will switch to static color mode if these keys are pressed while in dynamic mode.

BATTERY

The remote operates on one CR2025 3V lithium coin cell battery.

REMOTE STORAGE

After each use, the remote may be stored in the hidden compartment found on the right side of the drip tray's extended front.

Dynamic Mode	22 modes
Static Color	20 colors
Brightness Grade	5 levels
Speed Grade	10 levels
Remote Control Distance	Up to 50 ft. (in open area)

Table 1 - RGB Lighting Specifications

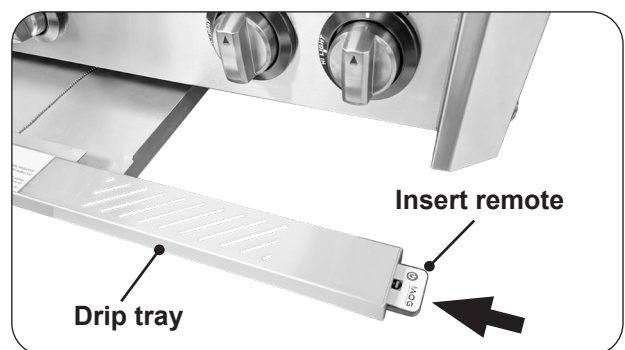

Fig. 36-2 Storage compartment

SERVICING AND CLEANING

Your grill requires regular cleaning and maintenance. Refer to these instructions for details. Performing these procedures will ensure proper operation, appearance, and safety.

WARNINGS

- Prior to servicing or cleaning make sure the unit is completely cool, the control knobs are turned to the OFF position, the gas supply is shut off, the light switch is off, and the power supply is disconnected (as applicable and unless otherwise stated).
- Wear appropriate gloves and safety glasses during any servicing or cleaning.
- DO NOT spray any cleaner or liquids on the grill when hot.
- The grill **MUST** be cleaned regularly to prevent grease build-up and other food deposits. A clean and well maintained grill prevents the risk of grease build-up and grease fires.
- Verify proper operation after servicing or deep cleaning.
- See INSTALLATION, OPERATION, AND SAFETY INFORMATION section for additional related information.

CLEANING YOUR GRILL

Before Each Use

1. **Inspect and clean the exterior surfaces of the unit:** With a cool grill, clean any dust, grease, splatter, or spills as needed with a damp clean cloth.

After Each Use

1. **Perform a burn-off and clean the cooking grids:** Operate the grill on high with the hood closed for 15 minutes to burn-off food and grease and allow for an easier cooking grid clean. Then turn OFF the grill and use a grill brush or scraper to clean the cooking grids of all residue. Use long-handled insulated BBQ tools and wear an insulated glove / oven mitt.
2. **Check and clean your drip tray:** When the grill is cool, carefully remove the drip tray and dispose of contents appropriately. Clean tray in a soapy water solution if needed. For tough deposits, a copper pad can be used. Rinse and dry completely.
3. **Cover your grill:** Once the grill is dry and cool, cover your grill with an AOG protective cover (not included).

Twice A Year (or as needed) - Deep Clean

1. **Interior of grill:** In addition to cleaning the cooking grids and drip tray, a deep clean of the interior of the grill, burners, and all components **MUST** be performed twice year (or as needed depending on use). Refer to the CARE, CLEANING, & MAINTENANCE GUIDE provided with your grill, or simply scan the QR code on the right.



Important: The burner ports and carry-over ports/slots **MUST** be kept clean to ensure proper ignition and operation. The guide provides all details on cleaning.

2. **Exterior of grill:** With a cool grill, use a grill cleaner (or a soapy water solution) and a clean cloth to remove grease and dirt from the outside of the grill. For tough deposits, a copper pad can be used. Always wipe with the grain. Rinse and dry completely. Then follow up with a stainless steel cleaner and a clean cloth. **DO NOT** use other cleaners or chemicals.

If this routine cleaning is not performed, the stainless steel may become dull and develop surface rust (due to use and atmospheric conditions). If left uncleaned, significant damage and pitting may occur.

Important: **DO NOT** use steel wool, any other metal tools, or any other cleaners/chemicals to clean the exterior other than recommended above. Such items promote rust.

Note: Due to the nature of stainless steel, temperatures produced by the grilling process will cause discoloration. This can be reduced by routine cleaning.



Fig. 37-1 Wipe with grain

SERVICING AND CLEANING (Cont.)

For Environments High In Salt, Chloride, Or Other Corrosive Chemicals

When this grill is installed in a corrosive environment such as near the ocean (salt air), poolside (chlorine and/or pool chemicals) or any other location with exposure to high salt/chloride content or corrosive chemicals/solutions, it will be more susceptible to corrosion and **MUST** be maintained/cleaned **more frequently**.

- **DO NOT** store any corrosive chemicals (chlorine, hydrochloric acid, fertilizer, etc.) near your stainless steel grill.
- **DO NOT** allow any corrosive materials (masonry dust, debris, etc.) to settle on your stainless steel grill.
- These environments, chemicals, and materials may cause the 304 stainless steel to develop surface rust and consequently pitting. Under these conditions the grill exterior **MUST** be cleaned at least monthly. Inspect your grill often and clean accordingly.

Protecting Your Grill

An optional AOG protective cover will protect your grill when not in use. Install the cover on a cool and dry grill. **DO NOT** cover a damp grill. During high humidity or after rainy conditions, remove the cover to dry trapped moisture if present. (If the cover is installed over a damp grill it can cause surface rust.)

Ensure that the **INSIDE** of the cover is DRY before putting it back on the grill.

SERVICING AND CLEANING (Cont.)

REPLACING HALOGEN BULBS (if equipped)

Your grill is engineered with the conveniences of electrical power for illuminating and igniting the grill.

To replace any interior oven light, follow the instructions below.

Important: ONLY REPLACE WITH 12V / 10 WATT HALOGEN BULB(S).

WARNING

To protect from potentially sharp sheet metal and glass, wear gloves and safety glasses during this procedure.

1. Turn all burner control knobs to the **OFF** position and shut off the gas supply to the grill at the source.
2. Disconnect supply of external electrical power to the grill.

CAUTION: Wait for the grill, oven, lens, light bulb, and fixture to cool before proceeding to the next step.

3. Open the oven lid.

Important: Place one hand directly below the glass lens and prepare to catch it when it is detached.

4. Carefully insert a standard flat head screwdriver or thin plastic spatula between the glass lens and the stainless steel on which the light is mounted and gently pry the glass lens out in such a way that the stainless steel is not scratched (twisting the screwdriver handle, for instance). Catch the lens and set it safely aside.

Note: You may wish to take this opportunity to clean the lens with a standard household window cleaner and then dry it completely.

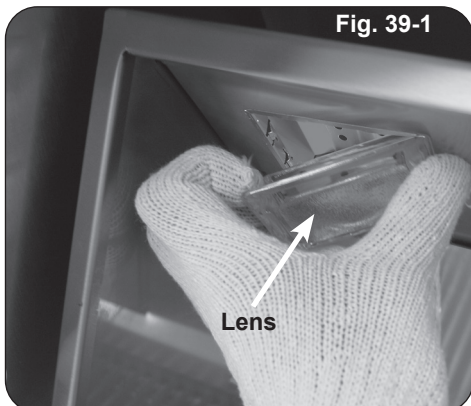

5. Wearing a pair of gloves, reach into the fixture, gently grab the bulb, and pull it straight out of the fixture so that the two pins at the base of the bulb come all the way out.

Important: Bulb is halogen. DO NOT TOUCH with bare hands. Oils from hands drastically reduce bulb life.

Note: It may be helpful to rock the bulb gently backward and forward while pulling it out.

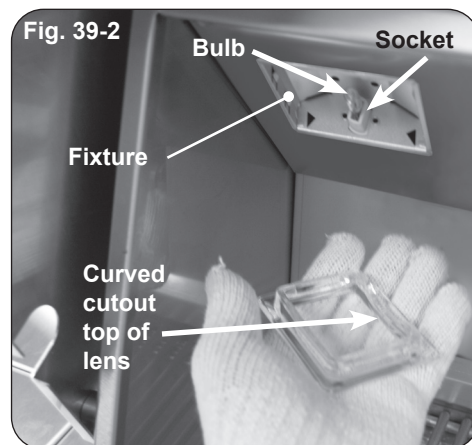

6. Inspect the old bulb for broken glass or filament.

Note: It may be beneficial to test a suspect bulb in one of the other light fixtures known to be working and turn the power back on to be certain the bulb is actually not working.

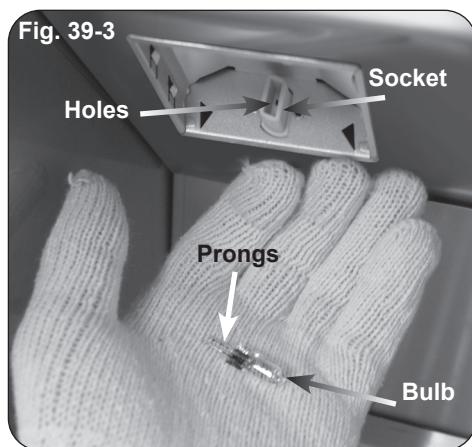

7. Insert the new **12V / 10 watt** halogen bulb into the socket so that both pins slide all the way into the two holes in the bottom of the socket.
8. Place the lens back into the fixture opening with the curved cutout on the bottom and snap it back into place.

FRONT FACE PANEL REMOVAL

1. Ensure all control knobs are in the OFF position and shut off the gas supply to the grill.
2. Pull the control knobs directly outward from the stems, and set them aside (see Fig. 40-1).
3. Using a Phillips-head screwdriver, loosen (do not fully remove) the fastener screws securing the control knob bezels (see Fig. 40-2, A).
4. Slide the bezels upward to free from the screws (Fig. 40-2, B), then pull outward to remove (Fig. 40-2, C).
5. Using both hands, grip the front face panel, carefully lift upward (Fig. 40-3, A), angle the top portion inward to unhook it (Fig. 40-3, B), then slide down and outward to remove (Fig. 40-3, C). If equipped, the LED light connector (Fig. 40-3, D) must be disconnected to free the face panel completely.
 - When removing the panel, take caution to not damage any wiring.
 - Whenever reconnecting any wires, apply a small amount of dielectric grease to the male connector, then make the connection. This will ensure conductivity and prevent moisture from affecting the contact.
 - During reinstallation; prior to opening the gas shut-off valve, be sure the control knob(s) are in the OFF position.



Fig. 40-1 Remove knobs

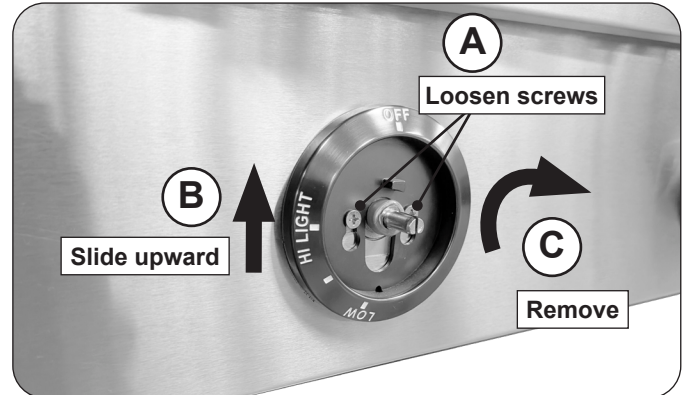

Fig. 40-2 Remove bezels

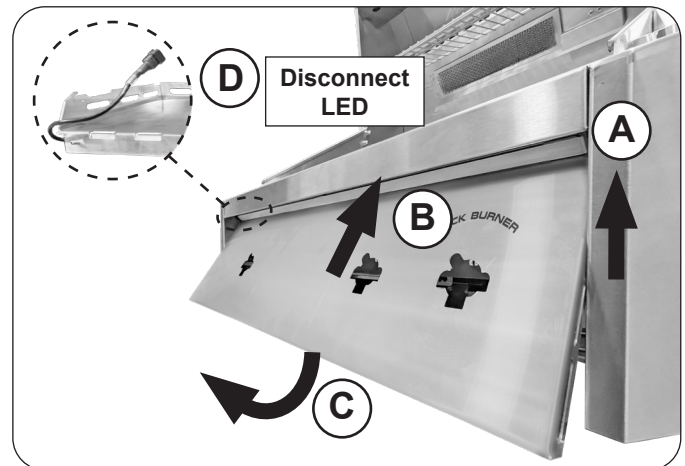

Fig. 40-3 Remove face panel

SYSTEM RESET

If the unit has power but the lights are not operating, the power supply may be in “protection mode” and will require a system reset.

1. Ensure the knobs are in the OFF position, the gas supply is turned off, and the light switch(es) are off.
2. Disconnect the harness from the power supply (see Fig. 41-1, A).
3. Disconnect the power supply from the power source. (see Fig. 41-1, B).
4. Check/replace any harnesses as needed.
5. Ensure the power GFCI breaker is reset.
6. Reconnect the power supply to the power source, then connect the harness to the power supply.
7. Test all components.

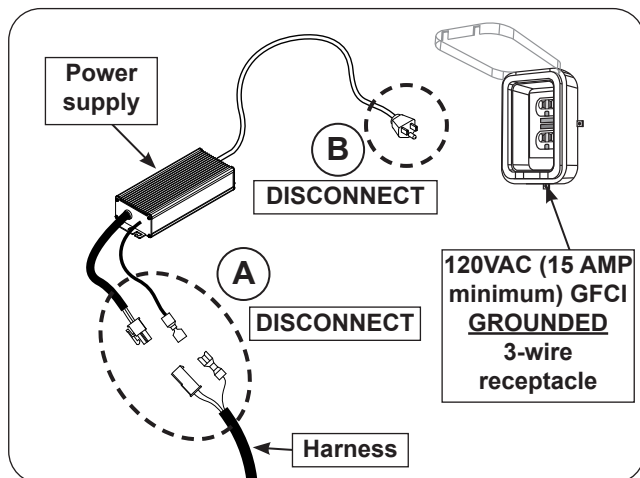

Fig. 41-1 Perform system reset

MAIN BURNER REMOVAL

1. Remove the cooking grid and vaporizer panel from above the burner that is to be removed and set them aside.
2. Locate the burner clip (located over the rear center tube of the burner) and slightly pinch and remove the clip from the burner support. See Fig. 41-2.
3. Carefully lift the burner from the burner support anchor peg holes and out from the hole in the forward fire wall.
4. To replace the burner, slide the open cylindrical end of the burner around the orifice, enveloping it and centering on it. Then lower the back end anchor pegs into the burner support anchor peg holes.

Note: It is critical to the continued safe functioning of the burners that the orifices are centered and completely inside the burner gas inlets.

5. Re-install the burner clip around the burner and into the holes in the burner support.
6. Replace the cooking grid and vaporizer panel..

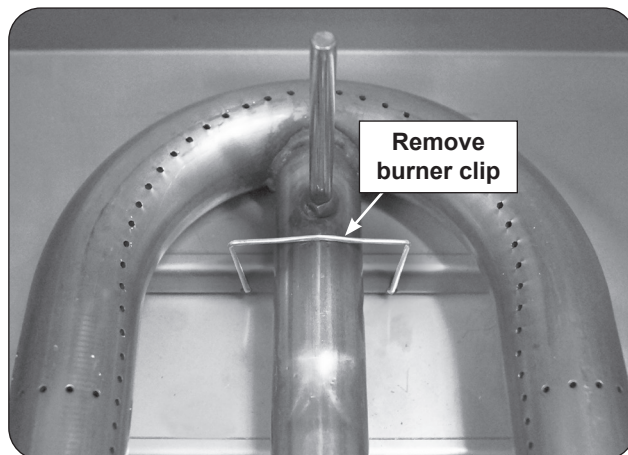

Fig. 41-2 Main burner removal

CONVERT GAS TYPE / CHECK BURNER ORIFICES

WHEN CONVERTING TO A NEW GAS TYPE, THE ENCLOSURE MUST HAVE PROPER VENTILATION FOR THE NEW GAS TYPE. See the ENCLOSURE REQUIREMENTS section for complete details.

CAUTION: Make sure the grill is at a safe temperature and isolated from gas and electrical supplies before beginning.

For your safety, exercise caution, and make sure you have adequate hand protection, such as gloves, when handling metal parts.

Apply Conversion Label

This grill comes from the factory configured for one type of gas as marked on the label behind the manifold channel.

When the grill is converted, the label for the new gas (included at original shipping) MUST be filled out and applied next to the existing label mentioned above.

Convert Regulator

The gas regulator, located beneath the grill, must be set for the type of gas used to fuel the grill. To check the regulator setting, remove the cap in the center of the regulator (Fig. 42-1, A). Holding the cap vertical (see Fig. 42-1, B), the letters at the bottom of the plastic stalk indicate the gas type for which the regulator is currently configured.

If the text on the bottom of the regulator stalk does not match the gas type connected to the grill, remove the stalk from the cap, invert, and replace into center of cap. Replace cap on the regulator, screwing down until snug.

Note: Models to be connected to household propane or natural gas lines require the regulator. For models to be connected to L.P. cylinders, the regulator is optional.

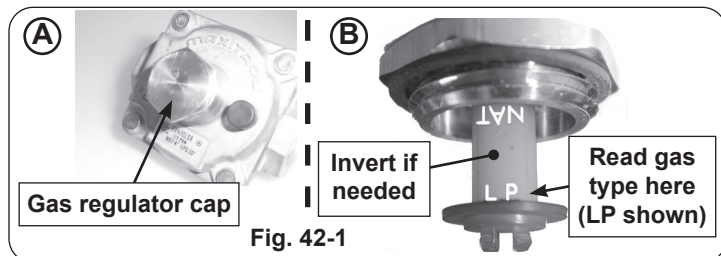

Fig. 42-1

Convert Gas Orifices

When converting the grill to a different gas type, each burner's orifice must be replaced with the corresponding orifice for the new gas.

See MODEL SPECIFICATIONS TABLE, Table 2 to determine the proper orifice sizes for each burner.

See the following sections for details on orifice conversion.

Important: It is critical to the operation of each burner that its orifice be fully inserted into the center of its orifice opening.

WARNING

HAZARDOUS OVERHEATING WILL OCCUR IF A NATURAL-GAS ORIFICE IS USED WITH PROPANE GAS.

Connect To New Gas Supply

Plumb the unit as appropriate for the new gas supply. (Additional components may be needed for your specific setup.) **Be sure to leak test at all connections.**

Convert/Check Main Burner Orifices

Note: It may be necessary to remove the rotisserie rod before beginning this procedure.

1. Remove the cooking grids and vaporizer panels and set them aside.
2. Remove the burners (see BURNER REMOVAL section for step-by-step instructions).
3. Use a 6mm hex deep socket nut driver to remove the exposed orifices. Access the orifices through the holes in the forward firebox plate inside the grill (see Fig. 42-2). Check orifices. If needed, replace all with the correct orifices for the new gas.

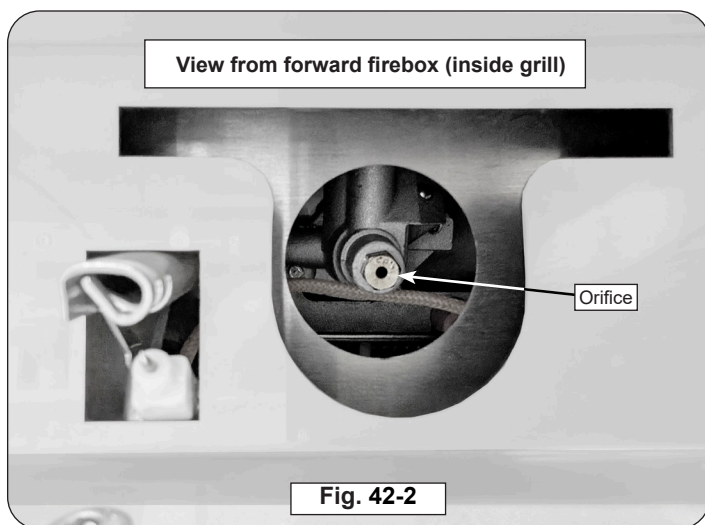
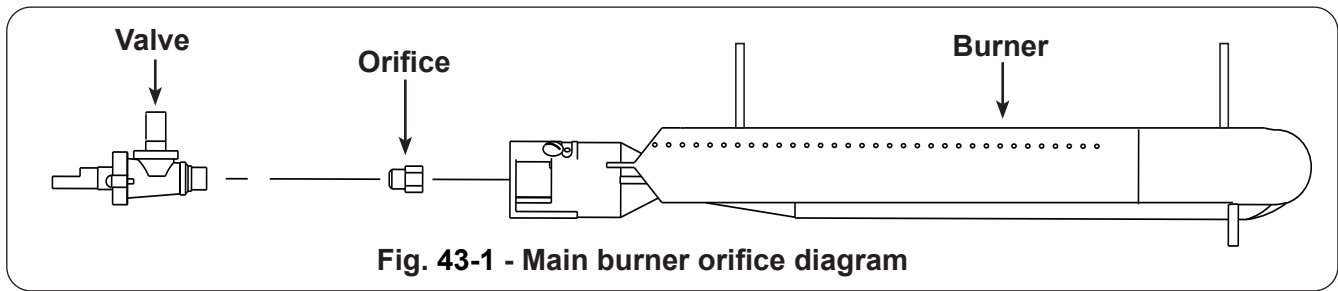

Fig. 42-2

Procedure continued on next page



4. Replace burners (See BURNER REMOVAL section).

Note: It is critical to the continued safe functioning of the burners that the orifices are centered and completely inside the burner gas inlets.

5. Replace the vaporizer panels and the cooking grids.

6. If applicable, reinstall the front panel.

Convert/Check Backburner Orifice (if equipped)

Note: It may be necessary to remove the rotisserie rod before beginning this procedure.

1. Remove the backburner mounting screws ($\frac{1}{4}$ " hex) located at the left end of the backburner assembly (see Fig. 43-2).
2. Carefully pull the left end of the backburner forward until the burner can be moved to the left pulling it free from the orifice located on the right side (see Fig. 43-3).
3. Use a $\frac{3}{8}$ " hex nut driver to remove the exposed orifice. Check orifice. If needed, replace it with the correct orifice for the new gas.
4. Replace the backburner assembly and the electrode by reversing the procedure in steps 1. through 2.

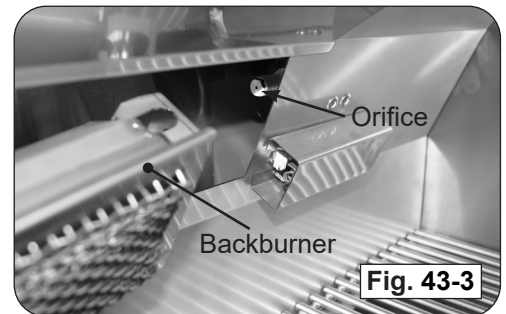
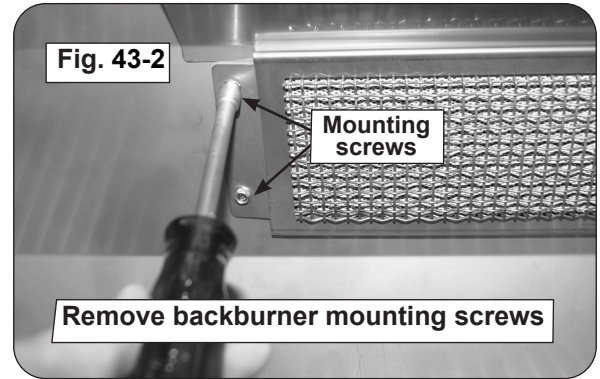

The backburner orifice can be seen on the right side after removing the backburner.

AIR SHUTTER ADJUSTMENT / BURNER FLAME INSPECTION

Important: Air shutters are preset at the factory (see Table 2 in MODEL SPECIFICATIONS). However, gas conversion, altitude, or other local conditions may make it necessary to adjust the air shutters.

Note: Backburner air shutters are not adjustable.

Note: To verify proper settings, the flames of the burners should be visually checked for proper flame appearance and behavior. Light the grill with the burner(s) on HI setting. Allow at least 2 minutes to burn. See below and Fig. 44-1. The flames should:

- be blue and stable with little to no yellow tips
- burn quietly, and appear to touch the burner

If the flames appear unstable, yellow, noisy, or lift away from the burner, follow the steps below.

Main Burner

Begin with a completely cool unit. Remove the burners (see BURNER REMOVAL section). First ensure the burner orifice, ports, venturi tubes, and air shutter openings are all clear of any insect or insect nests. If they are blocked, clean them, reinstall the burners, and reinspect the flames. If adjustment is still needed, **allow the unit to cool**, remove the burner, and proceed to the steps below.

1. To adjust the air shutter, loosen the adjustment screw with a flathead screwdriver. Then rotate the shutter to open or close it. See Fig. 44-2 for details.
 - Begin with the appropriate factory setting for your model (see Table 2 if needed).
 - If the flames were excessively yellow (insufficient air), open the shutter to allow more air to the burner. If the flames were noisy and lifting off the burner in some areas, close the shutter to allow less air to the burner. Adjust accordingly.

Note: Make minimal adjustments. Very small changes result in major changes in flame appearance.

2. Reinstall the burner, light the grill with the burner on HI, and observe the flames. If needed, allow the grill to completely cool, and repeat the adjustment process until the proper flame is achieved.
3. Once finished, allow the unit to completely cool, remove the burner, and tighten the adjustment screw. Reinstall the burner.
4. Repeat for all other main burners as needed.
5. Reinstall all other components that were removed.

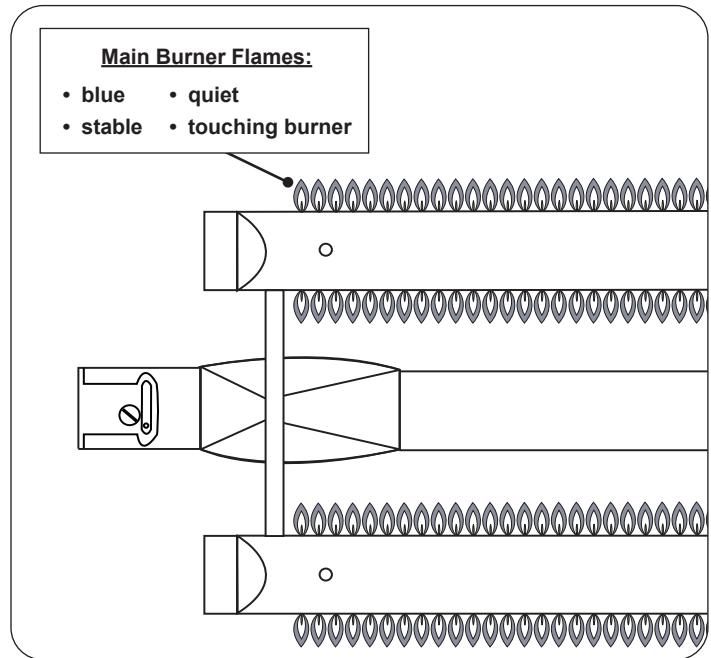

Fig. 44-1 Proper flame appearance

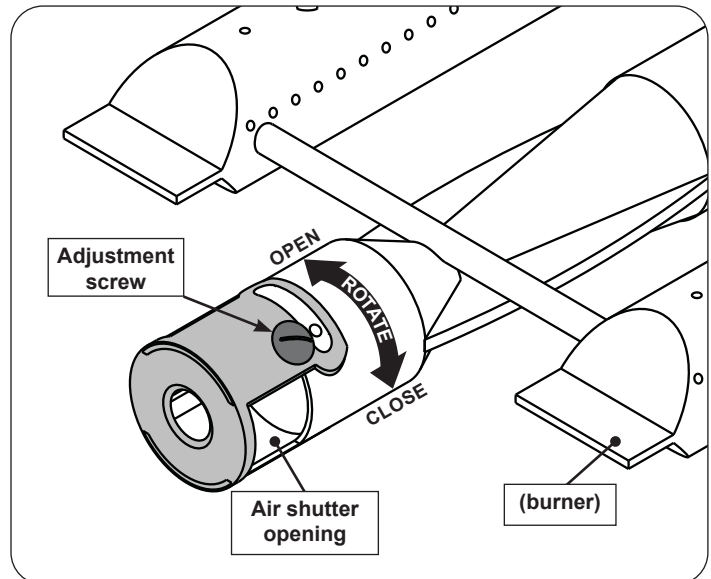

Fig. 44-2 Main burner air shutter adjustment detail

VALVE "LOW" SETTING ADJUSTMENT

Stability of the "low" setting on all burners may vary due to wind direction, appliance configuration, and position. If your burner goes out when set on low, the valve "low" setting needs adjustment.

Note: Adjustments MUST only be performed by a qualified professional service technician.

To adjust the valve "low" setting:

1. Ensure the unit is completely cool and the knobs are in the OFF position.
2. Remove the cooking grids and vaporizer panels.
3. Light the burner on HIGH, then turn the burner to LOW setting.
4. While the burner is on and set to LOW, remove the corresponding control knob.
5. Loosen the two screws that are securing the control knob bezel, then shift the bezel upward to free it from the screw heads, and remove.
6. Locate the FLATHEAD adjustment screw located on the upper left of the valve stem (see Fig. 45-1).
7. Using a flathead screwdriver, slowly turn the adjustment screw a little at a time (30° to 45°) in either direction. Adjust the screw as needed until the flame is approximately 1/4" in height from all the burner ports, and the flames are stable.
8. Once the appropriate setting is reached, re-install the bezel, the control knob, and shut off the burner valve.
9. Repeat this procedure for other burner valves, if needed.
10. Re-install the vaporizer panels, cooking grids, and any other components that were removed.

CONTROL KNOB FITMENT ADJUSTMENT

If a control knob needs to be adjusted for a sturdy fit, follow the steps below:

1. Gently pull the knob off the stem.
2. Insert a flathead screwdriver into the split portion of the stem and GENTLY turn the screwdriver clockwise. Be cautious! Only a slight turn is needed as the stem is flexible. See Fig. 45-2.
3. Check fitment by reinstalling the control knob, and adjust further (if needed).

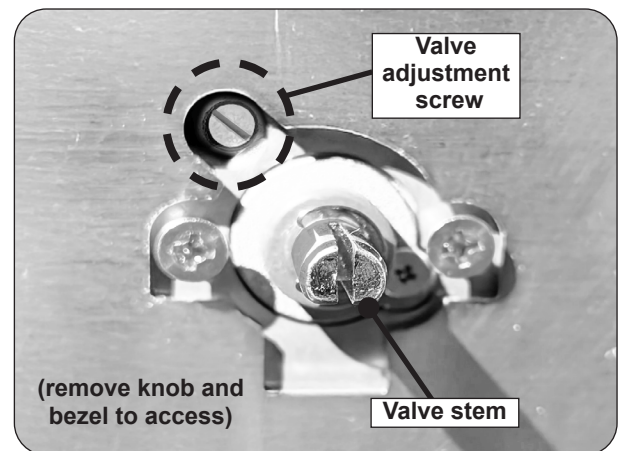

Fig. 45-1 Valve adjustment screw location

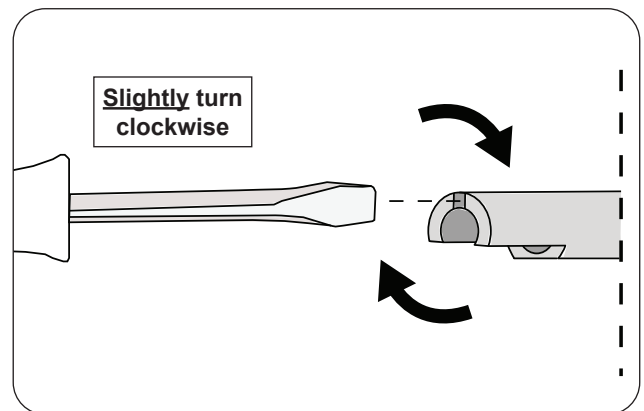

Fig. 45-2 Stem adjustment

Please use this page to record any information about your unit that you may want to have at hand.

TROUBLESHOOTING

If you have trouble with the unit, please use this list to identify the problem. By trying one or more of the solutions to the possible cause, you should be able to solve the problem. If this list does not cover your present problem, or if you have other technical difficulties with the unit, please contact your local dealer.

PROBLEM	POSSIBLE CAUSE	CORRECTION
Ignition system failure	<ol style="list-style-type: none"> 1. Improper air shutter adjustment 2. No spark generated at the valve 3. Low gas pressure 4. Front carry-over ports clogged 5. Igniter malfunction 	<ol style="list-style-type: none"> 1. Adjust air shutters. 2. Retry to light. If ignition failure continues, contact dealer for valve replacement. 3. Have the gas co. check supply pressure. 4. Clean burner ports. 5. Contact dealer for replacement.
Insufficient heat / low flame	<ol style="list-style-type: none"> 1. Burner ports clogged 2. Improper air-shutter adjustment 3. Using propane orifice for natural gas 4. Low gas pressure/flame (propane) 5. Low gas pressure/flame (natural) 6. L.P. regulator hose stuck/damaged 	<ol style="list-style-type: none"> 1. Remove burners and clean out ports. 2. Adjust air shutters. 3. Check/change orifices. 4. Refill propane tank, or reset propane tank safety*: Shut off all valves (including propane tank) and follow lighting instructions exactly. 5. Have a qualified professional service technician check for proper gas supply, setup, and pressure. 6. Replace L.P. regulator hose.
Uneven heating	<ol style="list-style-type: none"> 1. Burner ports partially blocked by debris 2. Small spiders or insects in burner 3. Improper air shutter adjustment 	<ol style="list-style-type: none"> 1. Remove burners and clean out ports. 2. Inspect burners and orifices for spider webs or other debris that may block flow. 3. Adjust air shutters.
Burner goes out on LOW	<ol style="list-style-type: none"> 1. Valve "Low" setting needs adjustment 	<ol style="list-style-type: none"> 1. See the VALVE "LOW" SETTING ADJUSTMENT section for details.
L-SERIES ONLY		
Interior oven lights and LED light strip not operating	<ol style="list-style-type: none"> 1. Light switch not functioning 2. Light switch / LED light / Oven lights not plugged in 3. Interior oven light(s) or LED light strip burned out 4. Input power source failure 5. Power supply failure 	<ol style="list-style-type: none"> 1. Re-connect external power to grill or contact dealer for replacement. 2. Remove front panel, check behind manifold channel, and re-connect as applicable. See FRONT FACE PANEL REMOVAL section. 3. Contact dealer for replacement. 4. Check GFCI / circuit breaker. 5a. Power supply in "protection mode" - see SYSTEM RESET section under SERVICING AND CLEANING. 5b. Replace power supply.
Rotisserie noisy	<ol style="list-style-type: none"> 1. Rotisserie out of balance 	<ol style="list-style-type: none"> 1. Adjust rotisserie counterbalance.

Note: *Propane tanks are equipped with a safety shutdown device that may cause low or no gas/flame at the burners if operating and lighting instructions are not followed exactly. **If you suspect the propane tank safety shutoff is in effect:** 1) Shut off all grill valves. 2) Shut off tank valve. 3) Open and close a main burner valve. 4) Open tank valve. 5) Follow the LIGHTING INSTRUCTIONS. Lighting instructions are located in the owner's manual and printed on the unit's metal drip tray. If the problem persists, continue troubleshooting, or contact your local dealer or distributor for assistance.

WARRANTY

AMERICAN OUTDOOR GRILL LIMITED WARRANTY

American Outdoor Grill warrants your grill to be free from defects in material and workmanship.

American Outdoor Grill stainless-steel burners and stainless-steel barbecue housings are warranted for **as long as the original purchaser owns them -- LIFETIME**.

American Outdoor Grill Diamond sear stainless-steel cooking grids are warranted for **FIFTEEN (15) YEARS**.

American Outdoor Grill valves, controls, manifolds and vent hood housings are warranted for **TEN (10) YEARS**. (Except as noted below.)

American Outdoor Grill backburners, rotisserie kits, vaporizer panels, and exterior Glass Fiber Reinforced Concrete (GFRC) grill island systems are warranted for **THREE (3) YEARS**.

American Outdoor Grill ignition systems (excluding batteries), electronic components (including vent hood controls and blowers), grill parts and accessories are warranted for **TWO (2) YEARS**.

A COPY OF YOUR SALES SLIP FOR PROOF OF PURCHASE IS REQUIRED

This warranty applies to the original purchaser for products which are installed in the United States or Canada and which are operated and maintained as intended for single family residential usage (if the unit is installed in a commercial / multi-user setting, a separate Commercial / Multi-User Limited Warranty applies and is available from RHP). This warranty is valid only with proof of purchase, commences on the date of purchase, and terminates (both as to original and any replacement products) on the anniversary date of the original purchase of the product per the above schedules.

This warranty **does not** cover parts which become defective as a result of negligence, misuse, or use not in compliance with the Installation and Owner's Manual, accidental damage, improper handling, improper storage, improper installation, **lack of required routine maintenance** (as specified in the Installation and Owner's Manual), electrical damage, local gas impurities or failure to protect against combustible materials. Product must be installed (and gas must be connected) as specified in the Installation and Owner's Manual by a **qualified professional installer**. This warranty **does not** apply to normal occurrences that may be expected with any outdoor product such as rust, corrosion, oxidation, or discoloration unless the affected part becomes inoperable. RHP products including valves, pilots and controls are designed and certified to be used as a system. Modifications to products which are not specifically authorized will void this warranty and could render the product to be unsafe. Burners, valves, parts, remotes, accessories, etc. used with this product must be RHP products or this warranty is void.

Warranted items will be repaired or replaced at RHP's sole discretion. This warranty **does not** cover labor or labor related charges, except as provided by separate specific written programs from RHP. All repair work must be performed by a qualified professional service person and requires prior approval of RHP.

RHP may require the defective product or part to be returned to the factory to determine the cause of failure. RHP will pay freight charges if the product or part is determined to be defective. This warranty does not cover breakage in shipment from our independent distributor to its customer if the damage is determined to have occurred during that shipment.

This warranty specifically excludes liability for **indirect, incidental, or consequential** damages. Some states and provinces do not allow the exclusion or limitation of incidental or consequential damages, so the above exclusion may not apply to you. This warranty gives you specified legal rights, and you may have other rights that vary from state to state or province.

For additional information regarding this warranty, or to place a warranty claim, contact the RHP dealer where the product was purchased.

When contacting your RHP dealer or the R.H. Peterson Co., please provide the following information:

- Your name, address, telephone number, e-mail
- Sales receipt showing where purchased and date purchased
- Model number, serial number of product, date code
- Relevant information: installer, additions, repairs, when defect was first noted

TO REGISTER YOUR PRODUCT ONLINE GO TO: WWW.AMERICANOUTDOORGRILL.COM, AND CLICK ON PRODUCT REGISTRATION. THANK YOU FOR YOUR PURCHASE.

Quality Check	Date: _____																									
<table style="width: 100%; border-collapse: collapse;"> <tr> <td style="width: 15%;">Burner Orifices</td> <td style="width: 10%;">Nat.</td> <td style="width: 10%;">L.P.</td> <td style="width: 15%;">Leak Test: _____</td> </tr> <tr> <td style="padding-left: 20px;">Main:</td> <td>_____</td> <td>_____</td> <td>Burn Test: _____</td> </tr> <tr> <td style="padding-left: 20px;">Back:</td> <td>_____</td> <td>_____</td> <td>Gas Type: <u>Nat. / L.P.</u></td> </tr> <tr> <td style="padding-left: 20px;">Side:</td> <td>_____</td> <td>_____</td> <td>Air Shutter: _____</td> </tr> <tr> <td>Infrared:</td> <td>_____</td> <td>_____</td> <td></td> </tr> <tr> <td style="padding-left: 20px;">Other:</td> <td>_____</td> <td>_____</td> <td>Inspector: _____</td> </tr> </table>	Burner Orifices	Nat.	L.P.	Leak Test: _____	Main:	_____	_____	Burn Test: _____	Back:	_____	_____	Gas Type: <u>Nat. / L.P.</u>	Side:	_____	_____	Air Shutter: _____	Infrared:	_____	_____		Other:	_____	_____	Inspector: _____	<div style="border: 1px dashed black; padding: 10px; margin-bottom: 10px;"> Model #: </div> <div style="border: 1px dashed black; padding: 10px;"> Serial #: </div>	
Burner Orifices	Nat.	L.P.	Leak Test: _____																							
Main:	_____	_____	Burn Test: _____																							
Back:	_____	_____	Gas Type: <u>Nat. / L.P.</u>																							
Side:	_____	_____	Air Shutter: _____																							
Infrared:	_____	_____																								
Other:	_____	_____	Inspector: _____																							